

2020

OS  
SO



a new way of living

20  
07

**COLECCION**

a new way of living



index



let's start

1



**Cake Menu**

CAKE FLAVORS	FROSTINGS & FILLINGS
Vanilla	Vanilla, Strawberry, Raspberry
Chocolate	Chocolate, Vanilla, Raspberry
Apple	Vanilla, Strawberry, Raspberry
Red velvet	Vanilla, Strawberry, Raspberry
Pumpkin	Vanilla, Strawberry, Raspberry
Blueberry	Vanilla, Strawberry, Raspberry
Orange	Vanilla, Strawberry, Raspberry
Peppermint	Vanilla, Strawberry, Raspberry
Key lime	Vanilla, Strawberry, Raspberry
Blackberry	Vanilla, Strawberry, Raspberry
Strawberry	Vanilla, Strawberry, Raspberry
Raspberry	Vanilla, Strawberry, Raspberry
Orange	Vanilla, Strawberry, Raspberry
Peppermint	Vanilla, Strawberry, Raspberry
Key lime	Vanilla, Strawberry, Raspberry
Blackberry	Vanilla, Strawberry, Raspberry
Strawberry	Vanilla, Strawberry, Raspberry
Raspberry	Vanilla, Strawberry, Raspberry

**PASTRY SHOP**

LATTE  
HOT CHOCOLATE  
CAPPUCCINO  
TEA  
ESPRESSO  
PICCOLO  
LONG  
FLAT WHITE  
LATTE MACCHIATO  
HOT CHOCOLATE  
CAPPUCCINO  
TEA

**ONE INDIA APARTMENTS**





# N



Ref. 001



Ref. 004



Ref. 005



Ref. 006



Ref. 007



Ref. 008M



Ref. 009



Ref. 010

Cores // Colores // Couleurs // Colors // Farben



REF.	H	A	H	H	H	C	Kg
001	86	55	52	45	4	0,33 / 3	4,65
004	86	55	52	45	-	0,25 / 2	4,90
005	86	55	52	45	4	0,33 / 4	6,40
006	86	53	54	45	4	0,29 / 2	5,70
007	86	48	52	45	-	0,25 / 2	4,50
008M	86	48	52	45	-	0,25 / 2	4
009	86	48	52	45	-	0,25 / 1	5,60
010	86	45	52	45	-	0,25 / 1	13,40



N



N





N



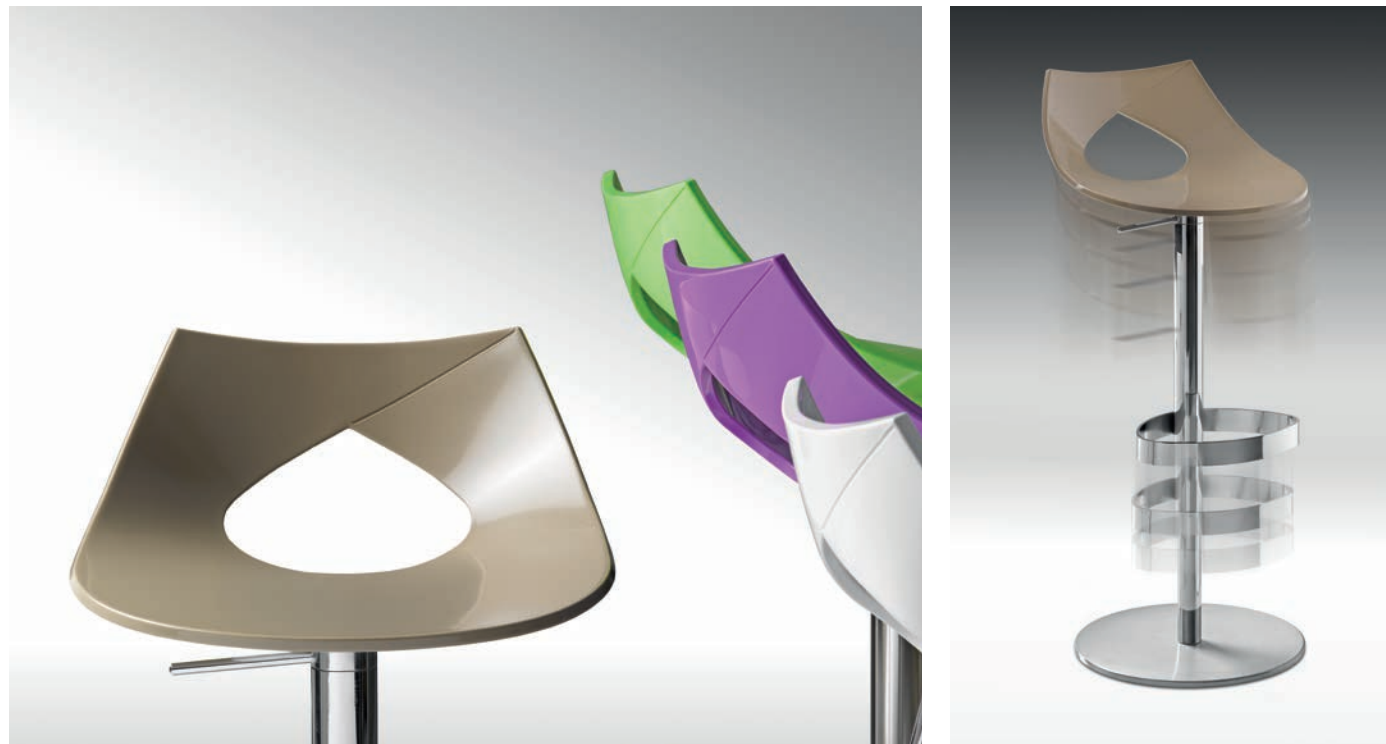

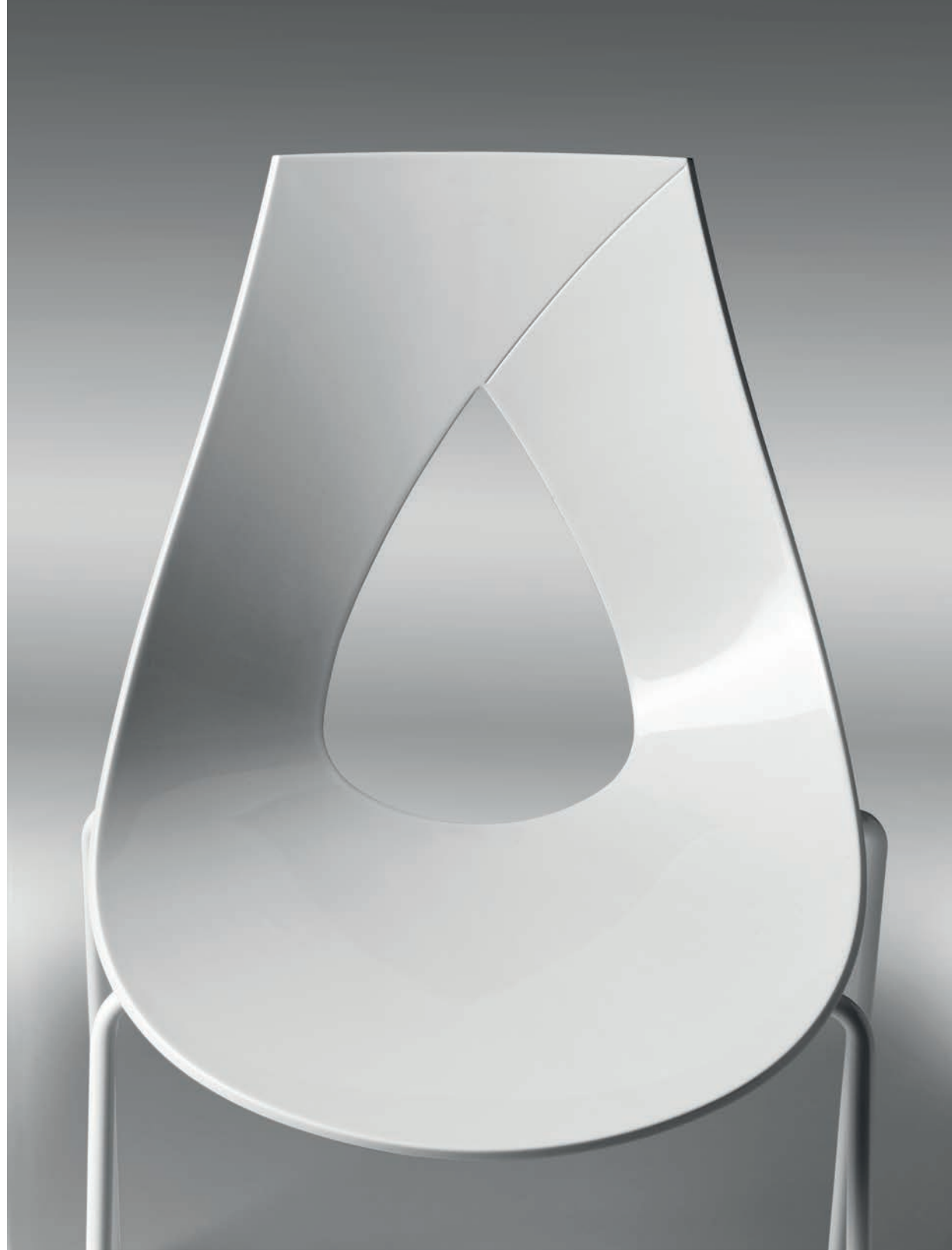

N



Ref. 011



Ref. 021



Ref. 024



Ref. 025



Ref. 026



Ref. 027



Ref. 018M



Ref. 028M

Cores // Colores // Couleurs // Colors // Farben



REF.	H	A	H	H	H	KG	KG
011	83	52	44	65	3	0,25 / 2	5,15
018M	83	47	45	65	1	0,25 / 1	4,10
021	93	52	47	75	3	0,25 / 2	5,25
024	93	42	47	75	-	0,25 / 1	5,70
025	93	42	46	75	-	0,25 / 1	18,10
026	94	42	46	75	-	0,25 / 1	13,40
027	72/97	42	46	55/80	-	0,25 / 1	15,80
028M	93	51	49	75	-	0,25 / 1	3,80



F



F





F



# F



Ref. 001



Ref. 005



Ref. 007



Ref. 008M



Ref. 009



Ref. 010

your  
choice

Cores // Colores // Couleurs // Colors // Farben



REF.	h	A	h	h	A	h	cube	kg
001	79	61	54	45	69	4	0,29 / 2	5,90
005	79	61	54	45	69	-	0,26 / 1	7,30
007	79	61	54	45	69	-	0,26 / 1	7,80
008M	79	61	54	45	69	-	0,26 / 1	5,80
009	79	61	54	45	69	-	0,26 / 1	7,30
010	79	61	54	45	69	-	0,26 / 1	15,90







Cores // Cores // Couleurs // Colors // Farben

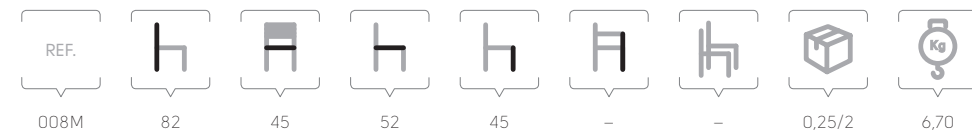
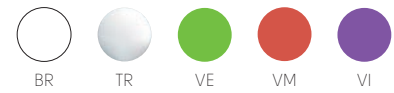

Ref. 008M

# B



Cores // Colores // Couleurs // Colors // Farben

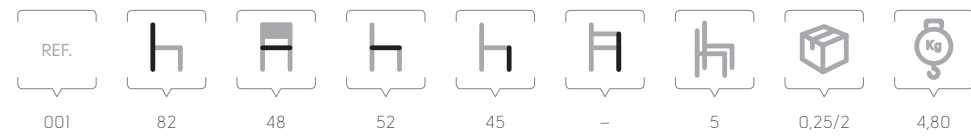

Ref. 001





Ref. 026

Ref. 027

Ref. 011

Ref. 021



Cores // Colores // Couleurs // Colors // Farben

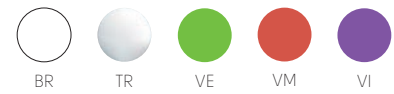

REF.	h	A	h	h	A	h	cube	Kg
002	82	53	52	45	66	3	0,32/3	6



Ref. 002

Cores // Colores // Couleurs // Colors // Farben



REF.	h	A	h	h	A	h	cube	Kg
011	102	46	58	65	-	-	0,25 / 1	6,80
021	112	46	58	75	-	-	0,37 / 1	7
026	112	46	58	75	-	-	0,25 / 1	16
027	95/120	45	58	57/82	-	-	0,25 / 1	18,50









Cores // Cores // Couleurs // Colors // Farben



Ref. BR

Ref. PR

Ref. BR/PR

Ref. BR/VM

Ref. BR/VI



Ref.001



Ref.005



Ref.006



Ref.009

REF.	h	A	h	h	A	h	kg	kg
001	80	59	56	45	64	2	0,29 / 2	7
005	80	59	56	45	64	-	0,29 / 1	7,40
006	80	59	56	45	64	-	0,26 / 1	8,20
009	80	59	56	45	64	-	0,26 / 1	6



K





K





Cores // Colores // Couleurs // Colors // Farben



Ref. 002



Ref. 008M

REF.	H	A	H	H	H	Box	Kg
002	88	55	56	46	-	0,29 / 1	9,80
008M	88	55	56	46	-	0,29 / 1	6,30

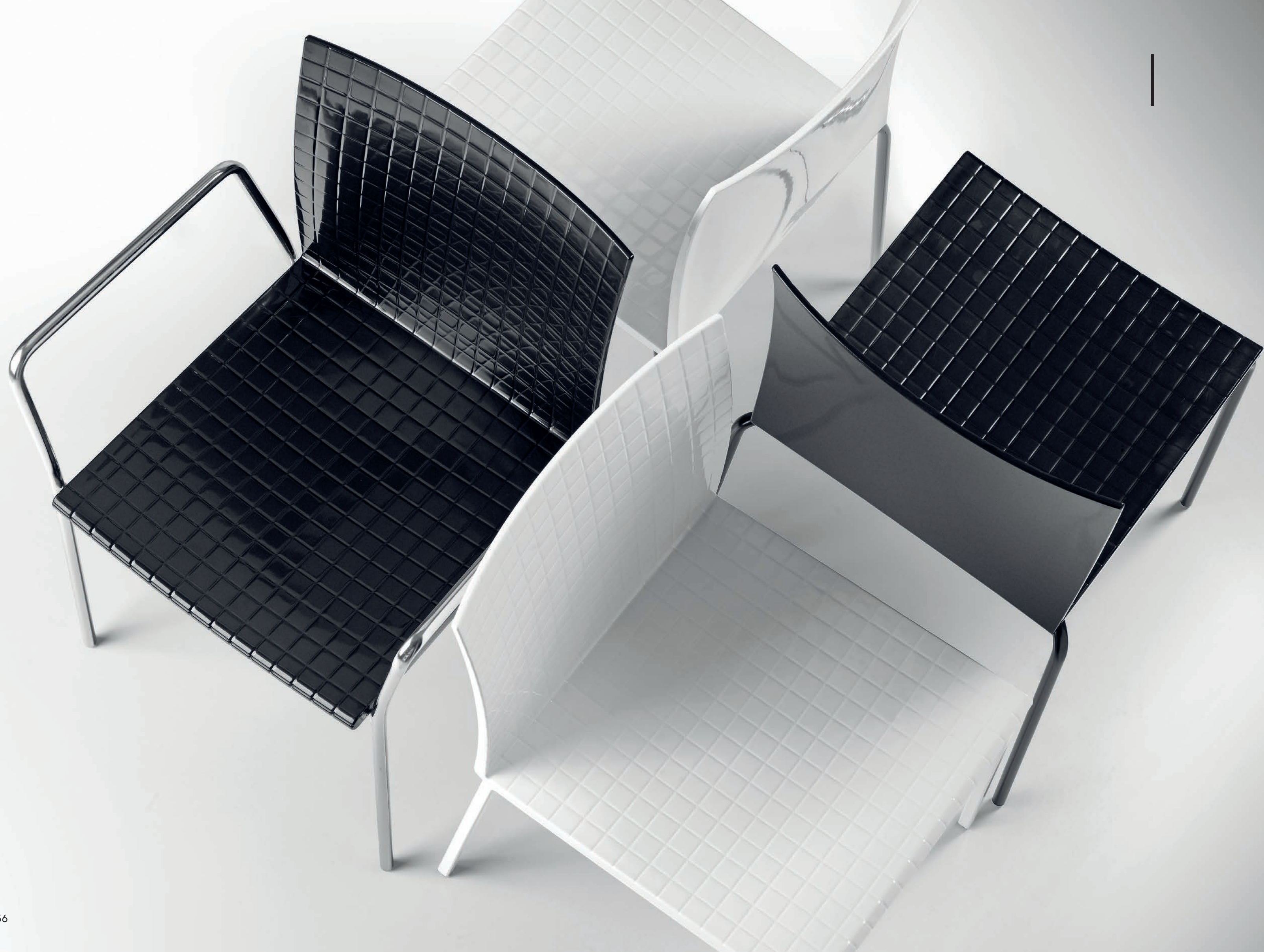



Ref. 001



Ref. 002



Ref. 003

Cores // Colores // Couleurs // Colors // Farben

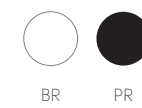

REF.	h	A	h	h	A	h	kg	kg
001	82	50	52	45	-	5	0,32 / 3	6
002	82	45	52	45	68	-	0,25 / 2	6,20
003	82	53	52	45	-	5	0,32 / 3	6,40



The Coffee

COFFEE MENU  
HOT DRINKS  
COLD DRINKS  
THE CHEAT WRAP  
WELLNESS SALAD  
HEALTHY WRAP & SANDWICHES  
WELLNESS WALK BOWL  
BAKERY  
SWEET



G



let's play



Ref. 001



Ref. 003



Ref. 006

REF.	H	A	H	H	H	Box	kg
001	81	50	52	45	4	0,32 / 3	5,30
003	81	50	52	45	4	0,25 / 3	4,70
006	81	50	52	45	4	0,32 / 3	6

Cores // Colores // Couleurs // Colors // Farben



P



P



Ref. 001

REF.								
001	71	52	58	44	70	5	0.35/3	6





A







A





Ref. 002

Cores // Colores // Couleurs // Colors // Farben

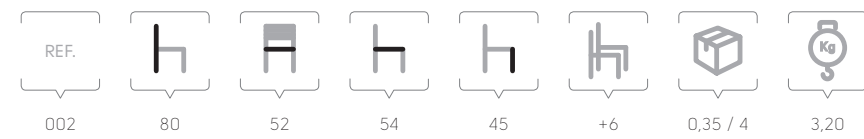





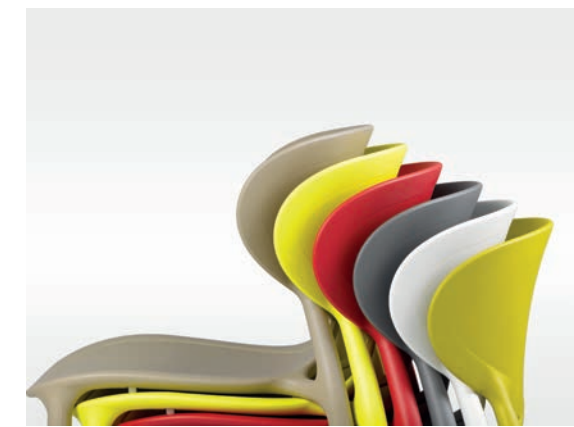

Cores // Cores // Couleurs // Colors // Farben

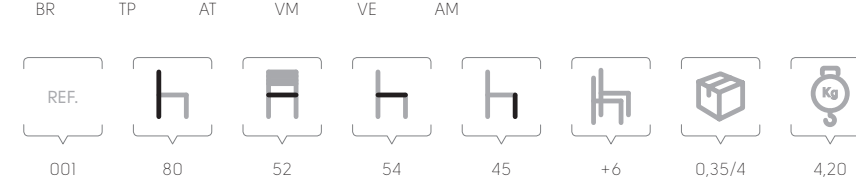

Ref. 001



P



Ref. 001

REF.							
001	85	66	58	43	-	0,32 / 1	8,10

Cores // Colores // Couleurs // Colors // Farben





let's  
chat

P



Ref. 001

REF.							
001	-	44	-	43	-	0,22 / 2	2,70

Cores // Colores // Couleurs // Colors // Farben



R



R



Cores // Colores // Couleurs // Colors // Farben

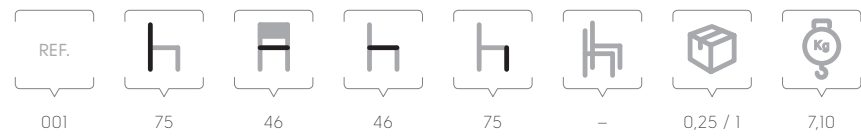

Ref. 001



W



really  
true



Ref. 001



Ref. 005



Ref. 006



Ref. 009

REF.								
001	80	53	52	45	64	-	0,27 / 1	5.90
005	80	53	52	45	64	-	0,27 / 1	8.20
006	80	53	52	45	64	-	0,27 / 1	10
009	83	53	52	45	64	-	0,29 / 1	8.20



S



S



REF.	h	A	h	h	h	⊡	Ⓚg
001	84	58	60	45	-	0,29 / 1	6,50
007	84	58	60	45	-	0,29 / 1	6,60



Ref. 001

Ref. 007

W



REF.								
008M	81	47	49	45	-	0,25 / 2	5,50	



Ref. 008M

M



REF.								
004M	82	46	53	45	-	0,32 / 2	5	



Ref. 004M

M



M



REF.							
008M	82	46	53	45	-	0,32 / 2	4,30



Ref. 008M





Ref. 001



Ref. 002



Ref. 005



Ref. 006



Ref. 008M

REF.	H	A	H	H	H	Box	kg
001	82	49	58	46	-	0,37 / 2	7
002	82	49	58	46	-	0,37 / 2	6,30
005	82	49	58	46	-	0,37 / 2	6,90
006	82	49	58	46	-	0,37 / 2	8,20
008M	82	49	58	46	-	0,37 / 2	5,90







P



Ref. 001

REF.								
001	88	45	57	48	-	0,25/2	8,5	



Ref. 001



Ref. 008M

REF.	h	A	h	h	h	h	h	kg
001	86	50	57	46	-	0,29 / 1	8,60	
008M	86	50	57	46	-	0,29 / 1	8,50	





Ref. 001



Ref. 008M

REF.	h	A	h	h	A	h	cube	kg
001	80	60	59	46	73	-	0,27 / 1	10
008M	80	60	59	46	73	-	0,27 / 1	9,90

N





M





M



Ref. 024



Ref. 026



Ref. 027



Cores // Colores // Couleurs // Colors // Farben



REF.	h	A	h	h	h	kg	kg
024	88	55	42	75	-	0,22 / 1	6,30
026	88	55	42	75	-	0,25 / 1	14,70
027	65 / 90	55	42	54 / 80	-	0,25 / 1	15,90

stay  
high



REF.	h	A	h	h	h	kg
018M	70	44	45	70	0,29 / 2	4
028M	80	46	49	80	0,30 / 2	3,6

T

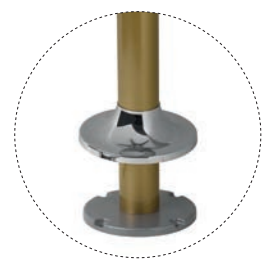

Ref. 025 ↻

REF.						
025	76	40	40	76	0,13 / 1	9,60

S



Ref. 025M ↻



Ref. 025E ↻

REF.						
025E 025M	76 76	40 40	40 40	76 76	0,22 / 1 0,22 / 1	19 19

P



Ref. 023

REF.						
023	76	37	37	76	0,13 / 1	10,30

N



Ref. 013



Ref. 023

REF.						
013 023	86 98	44 44	48 48	64 76	0,25 / 1 0,25 / 1	7,40 7,90



Ref. 002

REF.	H	A	H	H	H	Icon	Icon
002	82	50	49	45	-	0,32 / 3	5,30
022	101	43	45	75	-	0,22 / 1	6
025	101	43	45	75	-	0,22 / 1	24,30

P



Ref. 025



Ref. 022



Ref. 022



Ref. 002



Ref. 025



REF.								
002	79	51	49	45	-	0,37 / 4	5,20	
022	103	49	44	75	-	0,22 / 1	6,70	
025	103	49	44	75	-	0,22 / 1	23,50	





T



REF.							
001	87	42	51	46	3	0,25 / 3	4,40



Ref. 001

let's  
meet

T



Ref. 001



Ref. 021

REF.	H	A	H	H	H	KG	KG
001	85	40	47	45	-	0,37 / 4	5,20
021	75	40	40	75	-	0,22 / 2	5,40

A



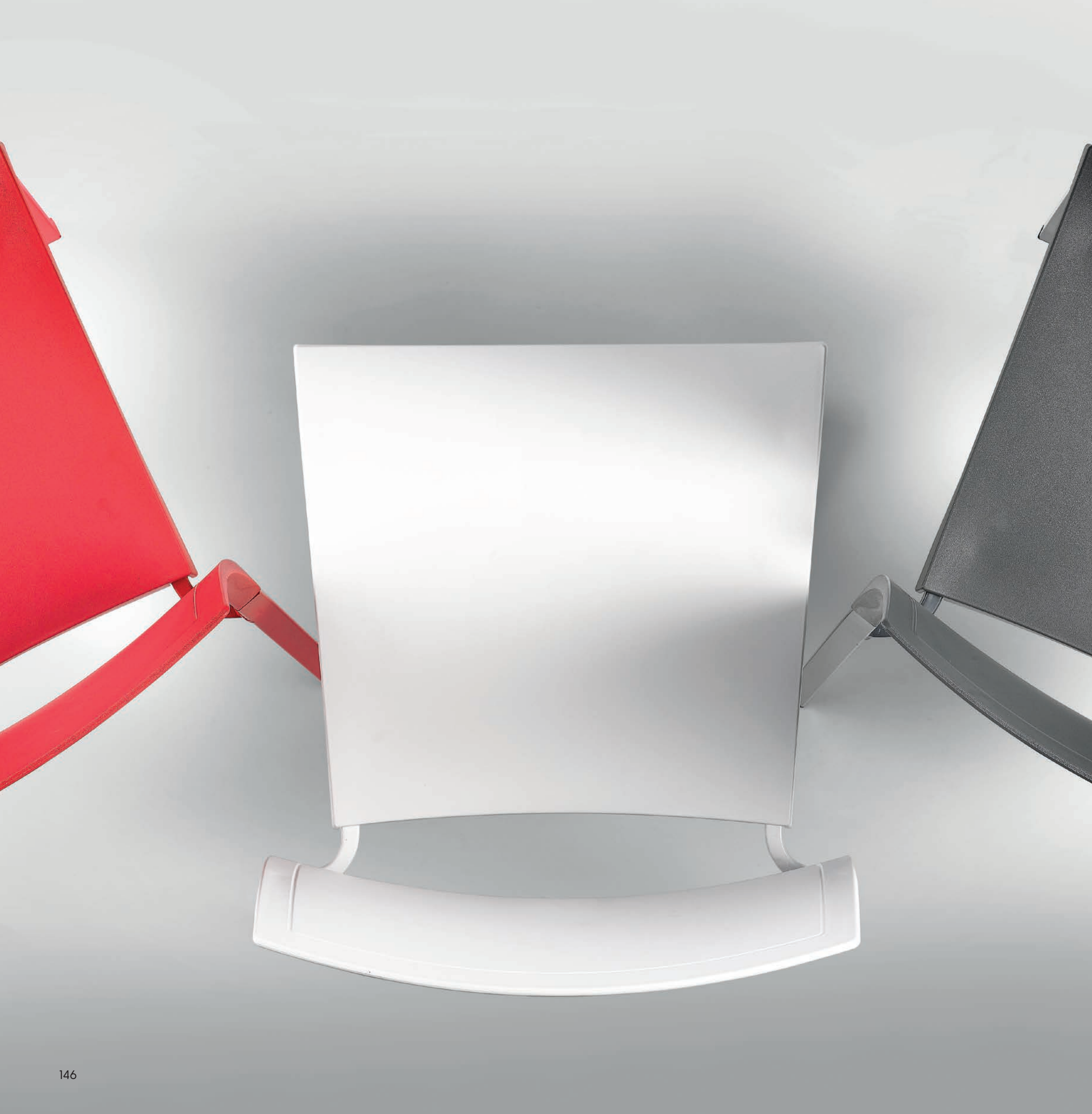

Cores // Colores // Couleurs // Colors // Farben

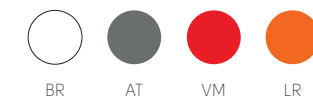

BR AT VM LR

Ref. 003

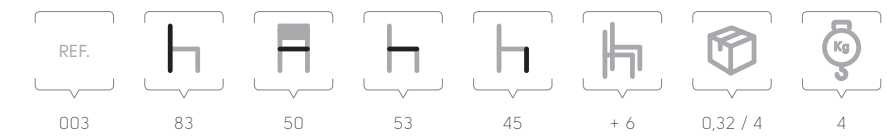



Ref. 001



Ref. 006

REF.	h	A	h	h	h	h	kg
001	87	53	53	46	4	0,32 / 3	4
006	87	50	54	46	4	0,32 / 2	4,90

Cores // Colores // Couleurs // Colors // Farben

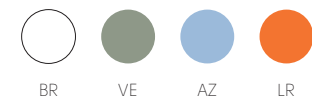

so  
simple



T

Cores // Colores // Couleurs // Colors // Farben



Ref. 001

Ref. 006

REF.							
001	63	38	37	37	+ 6	0,22 / 7	2,10
006	63	40	39	37	+ 4	0,25 / 6	2,40



A



Ref. 001



Ref. 006

Cores // Colores // Couleurs // Colors // Farben



REF.								
001	76	46	53	45	+ 6	0,25 / 4	2,90	
006	75	50	50	46	4	0,32 / 3	4,10	



# E



REF.	h	A	h	h	h	h	h	h
001	80	43	49	45	6	0,25/3	3,70	
002	70	42	42	38	6	0,25/5	3,20	



Ref. 001

Ref. 002

YOU ARE IN  
FIRST FLOOR  
**C**  
1  
OB TRIAGE  
LOBBY C  
MATERNAL FETAL  
MEDICINE CENTER  
CHILDREN'S  
EMERGENCY  
ADULT  
EMERGENCY



Med C  
health and

N



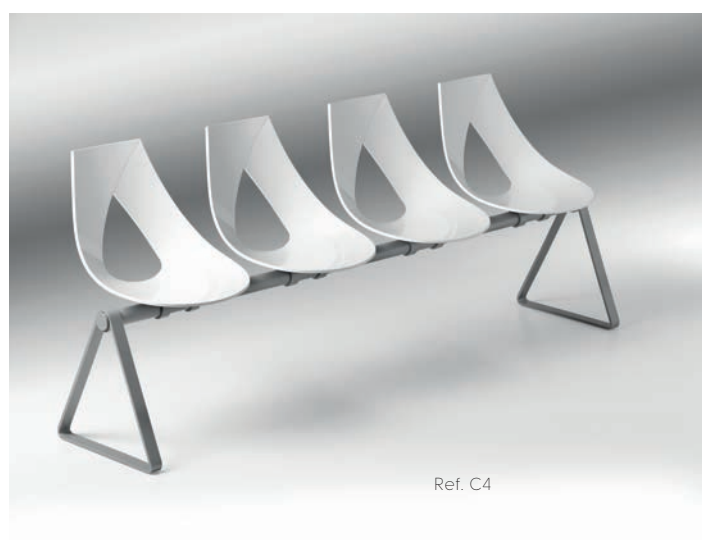
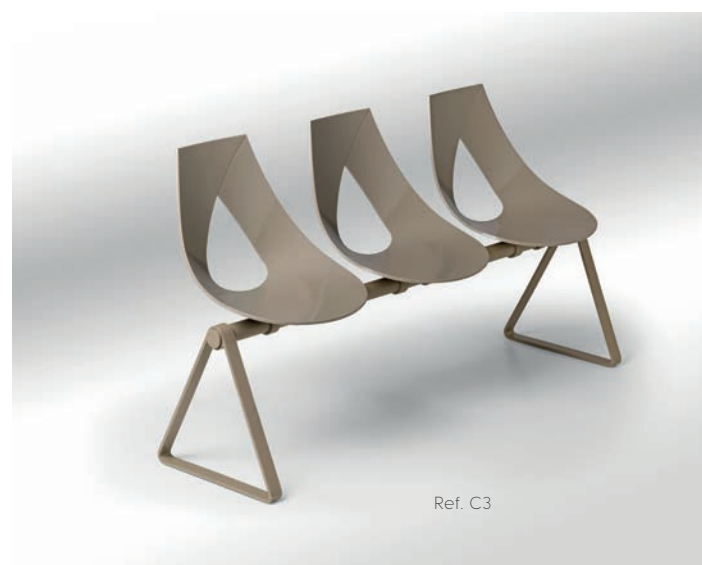

REF.						
C2	85	105	56	45	0,58	23
C3	85	158	56	45	0,87	29
C4	85	212	56	45	1,15	32,5
C5	85	264	56	45	1,43	36
CA2	85	105	56	45	0,58	15,5
CA3	85	158	56	45	0,87	21,5
CA4	85	212	56	45	1,15	25
CA5	85	264	56	45	1,43	28,5

Cores // Cores // Couleurs // Colors // Farben

BR
 TP
 AT
 PR
 VE
 VI



Cores // Cores // Couleurs // Colors // Farben



REF.						
C2	78	130	54	45	0,64	26
C3	78	195	54	45	0,95	33,5
C4	78	260	54	45	1,26	38,5
CA2	78	130	54	45	0,64	18,5
CA3	78	195	54	45	0,95	26
CA4	78	260	54	45	1,26	31





Ref. CA2



Ref. CA5



Ref. CA3



Ref. CA4

REF.	h	A	h	h	kg	kg
CA2	83	102	56	45	0,55	18,5
CA3	83	152	56	45	0,81	26
CA4	83	202	56	45	1,08	31
CA5	83	152	56	45	1,34	36

Cores // Colores // Couleurs // Colors // Farben



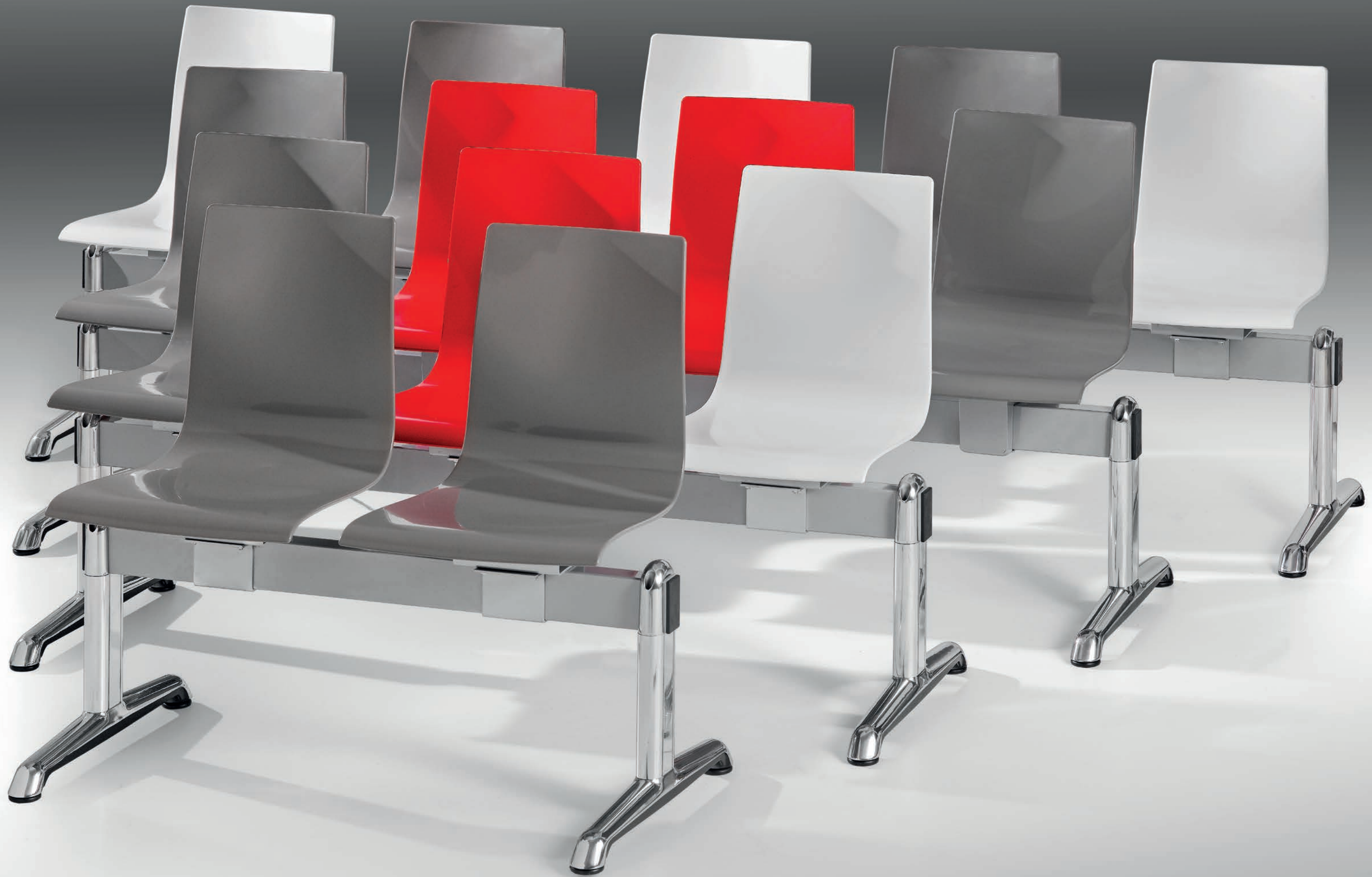



Ref. CN2



Ref. CN3



Ref. CN5



Ref. CN4



REF.						
CN2	83	102	56	45	0,55	25
CN3	83	152	56	45	0,81	32
CN4	83	202	56	45	1,08	37
CN5	83	252	56	45	1,34	41

Cores // Colores // Couleurs // Colors // Farben

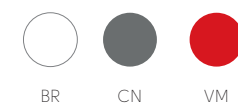

let's talk



TAK 001



Ø 400



-



Ø 800 - 700x700



730



0,12 / 1



8,1



Ref. 001



J



Cores // Colores // Couleurs // Colors // Farben



BR VE LR



Ref. 001

REF.	I	I	I	I	☐	⚖
JARRA 001	Ø 270	-	Ø 700	750	0,29 / 2	9

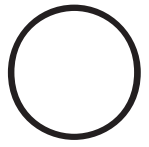
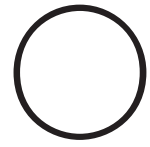

REF.  
ONDA 070

Ø 700

-

Ø 1300

730

0,36 / 1

13



Ref. 070



REF.  
OVA 084

800X400

Ø 60

1600X800

730

0,25 / 1

30



Ref. 084

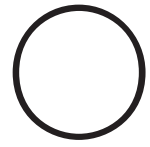

Ref. 070



Ref. 150



Ref. 050

REF.	I	I	I	I		
OLIMPIC 050	Ø 500	Ø 50	Ø 900	730	0,15 / 1	11
OLIMPIC 070	Ø 700	Ø 60	Ø 1300	730	0,15 / 1	14,5
OLIMPIC 150	Ø 500	Ø 50	Ø 700	1080	0,20 / 1	12



F



Ref. 011



Ref. 001

REF.						
FIXA 001	Ø 235	Ø 80	700X700	730	0,05 / 1	10,5
FIXA 011	Ø 235	Ø 80	700X700	1080	0,07 / 1	12

R



REF.						
RING 060	Ø 600	Ø 76	Ø 1200	730	0,10 / 1	26



Ref. 060



# E



Ref. 012



Ref. 002



Ref. 003

REF.	Table Top Dimensions	Table Top Thickness	Table Top Material	Table Height	Table Width	Table Depth	Weight (Kg)
EIFFEL 002	430X430	Ø 16	700X700	730	0,15 / 1	7,5	
EIFFEL 003	1080X430	Ø 16	1200X800	730	0,35 / 1	9,5	
EIFFEL 012	430X430	Ø 16	600X600	1080	0,20 / 1	8,5	

X



Ref. 003



Ref. 012



Ref. 002

REF.	Tabletop	Leg Diameter	Tabletop Dimensions	Tabletop Thickness	Weight	Weight
XENA 002	400X400	Ø 50	700X700	730	0,12 / 1	7,5
XENA 003	940X400	Ø 50	1200X700	730	0,28 / 1	14
XENA 012	400X400	Ø 50	600X600	1080	0,18 / 1	8,5

C



Ref. 001

REF.	Tabletop	Leg Diameter	Tabletop Diameter	Tabletop Thickness	Weight	Weight
CRYSLIDE 001	Ø 640	-	Ø 700	730	0,30 / 1	11,5



Ref. 001

Ref. 002

Ref. 003

REF.	Ø	Ø	Ø	H	Box	Weight
LUXOR 001	Ø 580	Ø 80	Ø 700	730	0,15 / 1	5,8
LUXOR 002	450X450	Ø 80	800X800	730	0,15 / 1	7,6
LUXOR 003	960X530	Ø 80	1200X800	730	0,38 / 1	12,5



Ref. 001

Ref. 002

Ref. 003

REF.	Ø	Ø	Ø	H	Box	Weight
LUXOR-M 001	Ø 580	Ø 80	Ø 700	730	0,15 / 1	5,6
LUXOR-M 002	450X450	Ø 80	800X800	730	0,15 / 1	7,4
LUXOR-M 003	960X530	Ø 80	1200X800	730	0,38 / 1	11,7

# R



Ref. 003

REF.	I	I	I	I	☐	⚖
RAZOR 003	1400X800	-	1400X800	730	0,35 / 1	38

# W



Ref. 002



Ref. 003

REF.	I	I	I	I	☐	⚖
WOOD-M 002 WOOD-M 003	700X700 - 800X800 1200X700 - 1200X800	- -	700X700 - 800X800 1200X700 - 1200X800	730 730	0,45 / 1 0,70 / 1	9 - 11 12 - 14

T



REF.	I	I	I	I	☐	⚖
THREE 001	Ø 660	Ø 60	Ø 800 - 700X700	730	0,32 / 1	13,5
THREE 011	Ø 660	Ø 60	Ø 700 - 600X600	1080	0,40 / 1	14,5



Ref. 011

Ref. 001



S



S



Ref. 001

Ref. 011

REF.							
STAR 001	Ø 450	Ø 70	Ø 900	730	0,32 / 1	20,5	
STAR 011	Ø 450	Ø 70	Ø 700	1080	0,40 / 1	21,5	

REF.							
STAR 002	400X400	Ø 50	800X800	730	0,32 / 1	13,5	
STAR 012	400X400	Ø 50	600X600	1080	0,40 / 1	14,5	



Ref. 002

Ref. 012

P



P



Ref. 040



Ref. 048

REF.  
PALMA 040  
PALMA 048

Ø 400  
Ø 480

Ø 80  
Ø 80

Ø 800 - 700X700  
Ø 900 - 800X800

730  
730

0,10 / 1  
0,10 / 1

14  
18

REF.  
PALMA 390  
PALMA 490

390X390  
490X490

70X70  
70X70

800X800  
1000X1000

730  
730

0,10 / 1  
0,10 / 1

16  
23,5



Ref. 390



Ref. 490

S



Ref. 040



Ref. 055

REF.						
STAIRS 040	Ø 400	Ø 80	Ø 800	730	0,15 / 1	18,6
STAIRS 055	Ø 550	Ø 80	Ø 1000	730	0,15 / 1	28

S



Ref. 6040



Ref. 400

REF.						
STAIRS 400	400X400	70X70	800X800	730	0,15 / 1	21,5
STAIRS 6040	600X4000	70X70	1200X800	730	0,15 / 1	30,5

F



Ref. 003



REF.	I	I	I	I	Kg
FOLD 003	-	Ø 30	1600X800	730	11,5



Ref. 002



REF.	I	I	I	I	Kg
IRIS 002 IRIS 003	Ø 800	60X60 50X50	Ø 1400 1600X800	730 730	14 12 / 15



Ref. 003



REF.	I	I	I	I		
CAMILA 002	480X480	50X50	700X700	730	0,18 / 1	6,3
CAMILA 012	480X480	50X50	600X600	1080	0,26 / 1	7,3



Ref. 002



Ref. 012



Ref. 002



Ref. 003

REF.	I	I	I	I		
FIRST 002	410X410	Ø 38	700X700	730	0,14 / 1	3,7
FIRST 003	790X540	Ø 38	1200X800	730	0,33 / 1	9,5

F



REF.	I	I	I	I	☐	⚖
001	800x800	∅ 50	800x800	730	0,10 / 1	11
003	1200x800	∅ 50	1200x800	730	0,15 / 1	15

S



REF.	I	I	I	I	☐	⚖
001	700x700	∅ 30	700x700	730	0,10 / 1	10
003	1100x700	∅ 30	1100x700	730	0,15 / 1	13



Ref. 011



Ref. 012

REF.	Width	Depth	Length	Height	Weight
ESCOLAR 011	630X480	Ø 40	700X500	580	7,4
ESCOLAR 012	1200X480	Ø 40	1300X500	580	8,4



Ref. 021



Ref. 022

REF.	Width	Depth	Length	Height	Weight
ESCOLAR 021	630X480	Ø 40	700X500	730	8,4
ESCOLAR 022	1200X480	Ø 40	1300X500	730	9,4

Z



Ref. 001

fix it





Ref. 002 [P. 202]



Ref. 012 [P. 202]



Ref. 001 [P. 187]



ef. 003 [P. 185]



Ref. 002 [P. 201]



Ref. 003 [P. 201]



LRef. 001 [P. 188]



Ref. 002 [P. 188]



Ref. 002 [P. 185]



Ref. 012 [P. 185]



Ref. 011 [P. 206]



Ref. 012 [P. 206]



Ref. 003 [P. 188]



Ref. 001 [P. 189]



Ref. 002 [P. 189]



Ref. 003 [P. 189]



Ref. 021 [P. 207]



Ref. 022 [P. 207]



Ref. 002 [P. 203]



Ref. 003 [P. 203]



Ref. 050 [P. 180]



Ref. 070 [P. 180]



Ref. 150 [P. 180]



Ref. 070 [P. 178]



Ref. 001 [P. 182]



Ref. 011 [P. 182]



Ref. 001 [P. 204]



Ref. 003 [P. 204]



Ref. 084 [P. 179]



Ref. 048 [P. 196]



Ref. 390 [P. 197]



Ref. 490 [P. 197]



Ref. 003 [P. 190]



Ref. 060 [P. 183]



Ref. 040 [P. 198]



Ref. 002 [P. 191]



Ref. 003 [P. 191]



Ref. 002 [P. 186]



Ref. 003 [P. 186]



Ref. 055 [P. 198]



Ref. 400 [P. 199]



Ref. 6040 [P. 199]



Ref. 001 [P. 194]



Ref. 012 [P. 186]



Ref. 001 [P. 209]



Ref. 002 [P. 195]



Ref. 011 [P. 194]



Ref. 012 [P. 195]



Ref. 001 [P. 205]



Ref. 003 [P. 205]



Ref. 001 [P. 174]



Ref. 001 [P. 192]



Ref. 011 [P. 192]

take  
me

# Carrinho





# Dispenser

alcohol gel

# Dispenser

alcohol gel

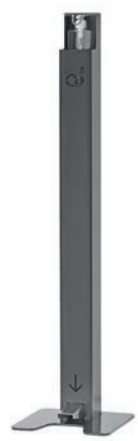

Ref. 001

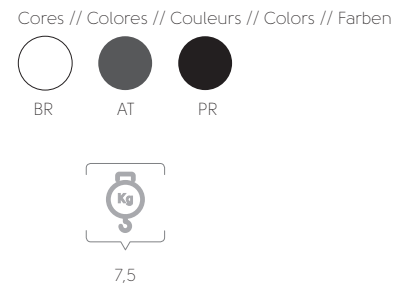
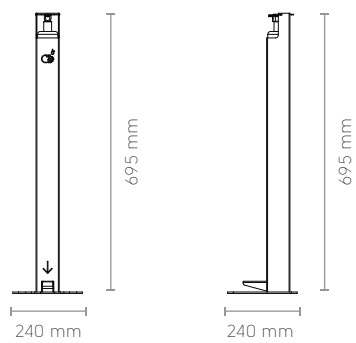

Coluna  
Colonne  
Column  
80x80 mm

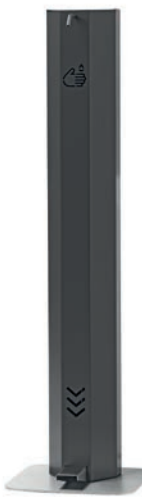

Ref. 020

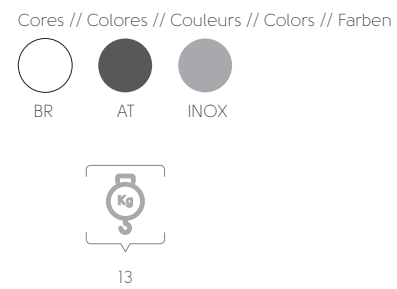
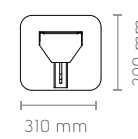
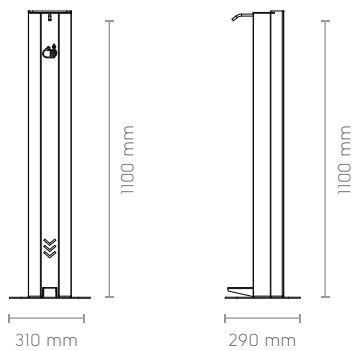



# acabados

ACABADOS | FINITIONS | FINISHINGS | AUSFÜHRUNG

## MADERA NATURAL VINTAGE

MADERA NATURAL VINTAGE | BOIS NATUREL VINTAGE | NATURAL WOOD VINTAGE | NATURHOLZ

TAMPOS | TABLEROS | PLATEAUX | TABLE TOPS | TISCHPLATTEN



PINHO • PINO • PIN • PINE • PINIE



FREIXO • FRESNO • FRÊNE • ASH • ESCHÉ



CARVALHO • ROBLE • CHÊNE • OAK • EICHE



CORES VINTAGE | COLORES VINTAGE | COULEURS VINTAGE | VINTAGE COLORS | VINTAGE FARBEN



VTG101



VTG103

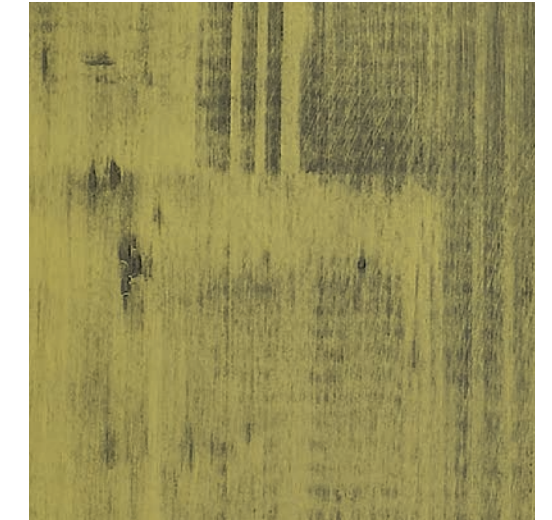

VTG105



VTG107



VTG109



VTG112

LAMINITES | LAMINADOS | STRATIFIÉ | LAMINATE | LAMINAT

LOW COST

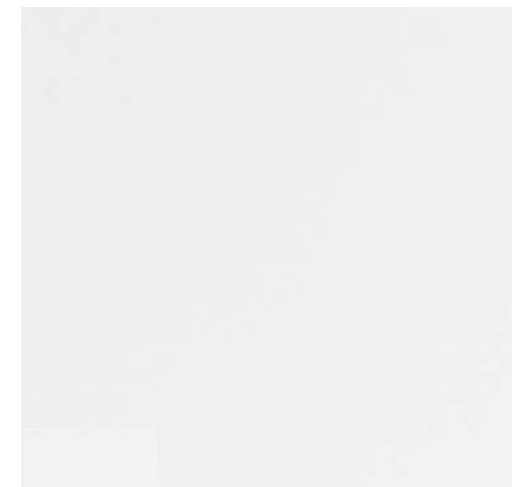

LC001



LC011

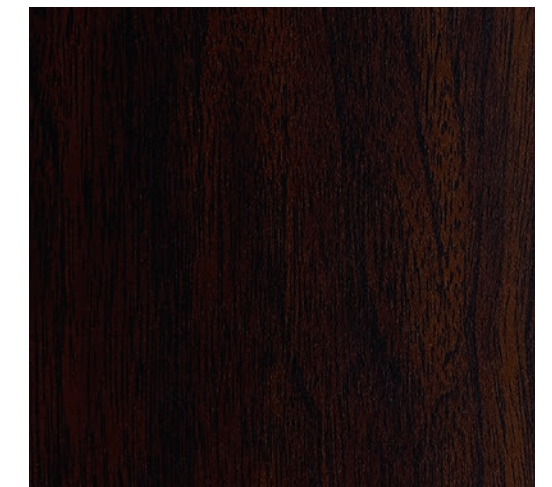

LC021

## MADERA NATURAL

MADERA NATURAL | BOIS NATUREL | NATURAL WOOD | NATURHOLZ

TAMPOS | TABLEROS | PLATEAUX | TABLE TOPS | TISCHPLATTEN



PINHO • PINO • PIN • PINE • PINIE



FREIXO • FRESNO • FRÈNE • ASH • ESCHE



CARVALHO • ROBLE • CHÈNE • OAK • EICHE

ref. **MPN30**

Madeira Pinho  
Madera Pino  
Bois Pin  
Wood Pine  
Holz Pine

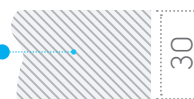

ref. **MFR30**

Madeira Freixo  
Madera Fresno  
Bois Frêne  
Wood Ash  
Holz Esche

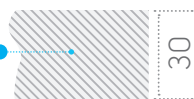

ref. **MCA30**

Madeira Carvalho  
Madera Roble  
Bois Chêne  
Wood Oak  
Holz Eiche

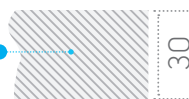

A madeira é um material vivo e é impossível evitar a formação de fendas, fissuras ou alteração de cores. Sem responsabilização pelas alterações acima mencionadas.

Importante: La madera es un material vivo y es imposible evitar la formación de grietas o alteración de colores. No nos hacemos responsables por cualquier alteración.

Le bois est une matière vivante et il est impossible d'empêcher la formation de gerces, de fentes, de craquelures ou changements de couleur.

Pas de responsabilisation par les déformations vu qu'elles sont incontrôlables.

Wood is a living material and it's impossible to prevent the formation of cracks, fissures or color changes. No liability for any deformation as they are uncontrollable.

Holz ist ein lebendiges Material und es ist nicht möglich die Bildung von Rissen oder Farbveränderungen zu verhindern. Keine Haftung für Verformungen, da diese nicht zu beeinflussen sind.

## BOIS DEBOUT

LAMINADOS | STRATIFIÉ | LAMINATE | LAMINAT

TAMPOS | TABLEROS | PLATEAUX | TABLE TOPS | TISCHPLATTEN



H1181 ST37



H1180 ST37



H3309 ST28



H1181 ST37 - PVC - CHANT FIL DE BOIS 30-44



H1180 ST37 - PVC - CHANT FIL DE BOIS 30-44



H3309 ST28 - PVC - CHANT FIL DE BOIS 30-44



H1181 ST37 - PVC - CHANT BOIS DEBOUT 30-44



H1180 ST37 - PVC - CHANT BOIS DEBOUT 30-44



H3309 ST28 - PVC - CHANT BOIS DEBOUT 30-44

ref. **ALBD1230**

Laminite  
Laminado  
Stratifié  
Laminate  
Laminat

Aglomerado  
Agglomerado  
Aggloméré  
Chipboard  
Holzspanplatte

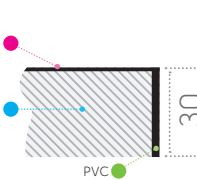

ref. **ALBD1244**

Laminite  
Laminado  
Stratifié  
Laminate  
Laminat

Aglomerado  
Agglomerado  
Aggloméré  
Chipboard  
Holzspanplatte

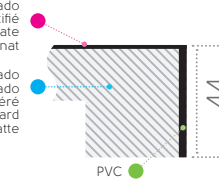



Los colores y dimensiones presentados en el catalogo son solamente para ejemplificación  
 Les couleurs et dimensions présentées dans le catalogue sont seulement pour exemplification  
 The colours and dimensions presented in the catalogue are just exemplifying  
 Die farben und größen im katalog sind nur exemplarisch

AF

TABLETROS | PLATEAUX | TABLE TOPS | TISCHPLATTEN

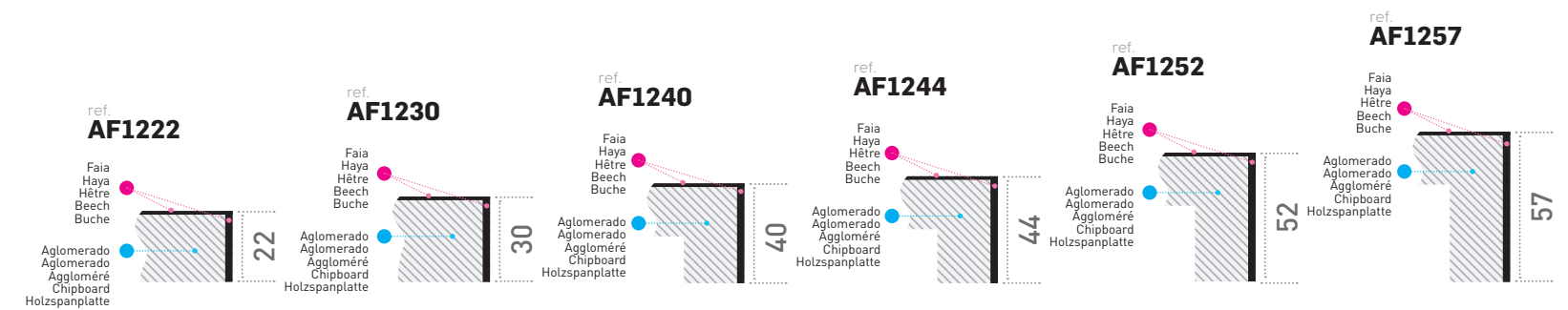

HAYA CON COLOR | HÊTRE TEINTÉ | STAINED BEECH | BUCHE GEBEITZT

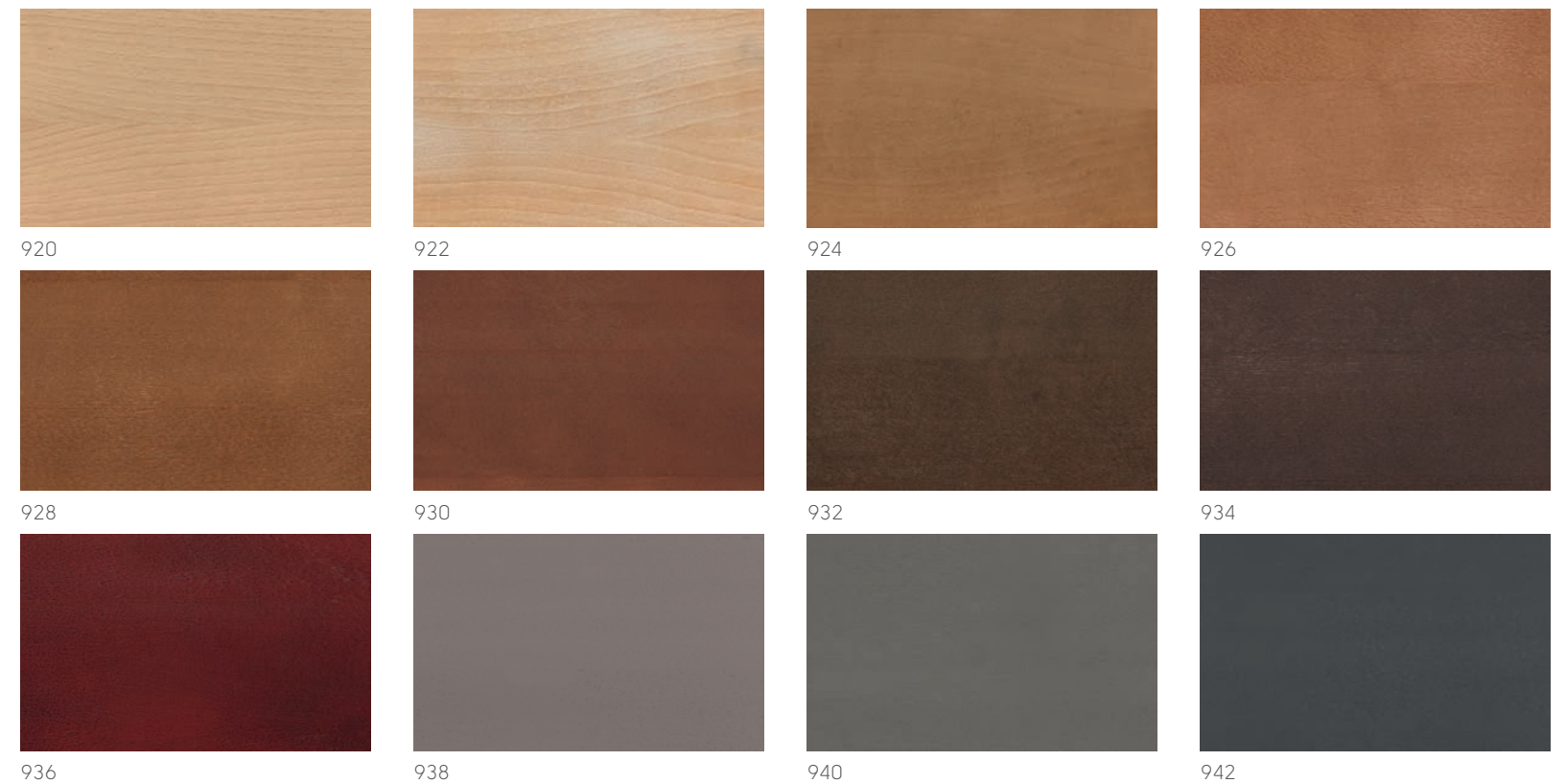





## ALPVC

| TABLEROS | PLATEAUX | TABLE TOPS | TISCHPLATTEN

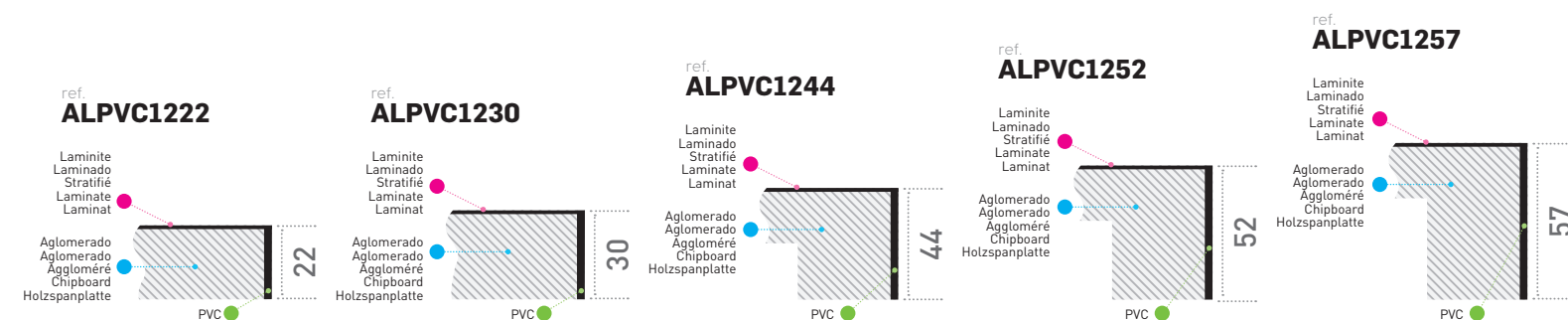

## TOPSLIM

by redi

| TABLEROS | PLATEAUX | TABLE TOPS | TISCHPLATTEN

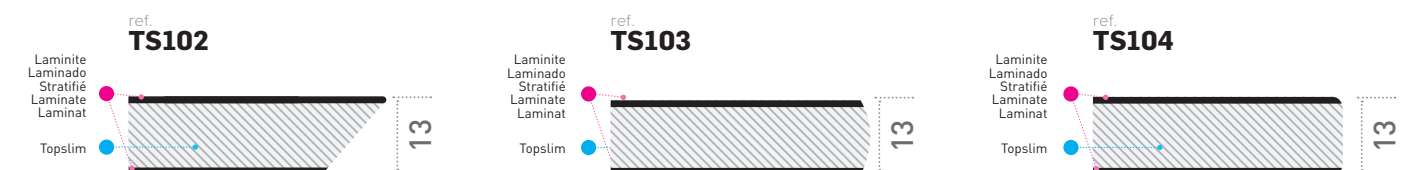

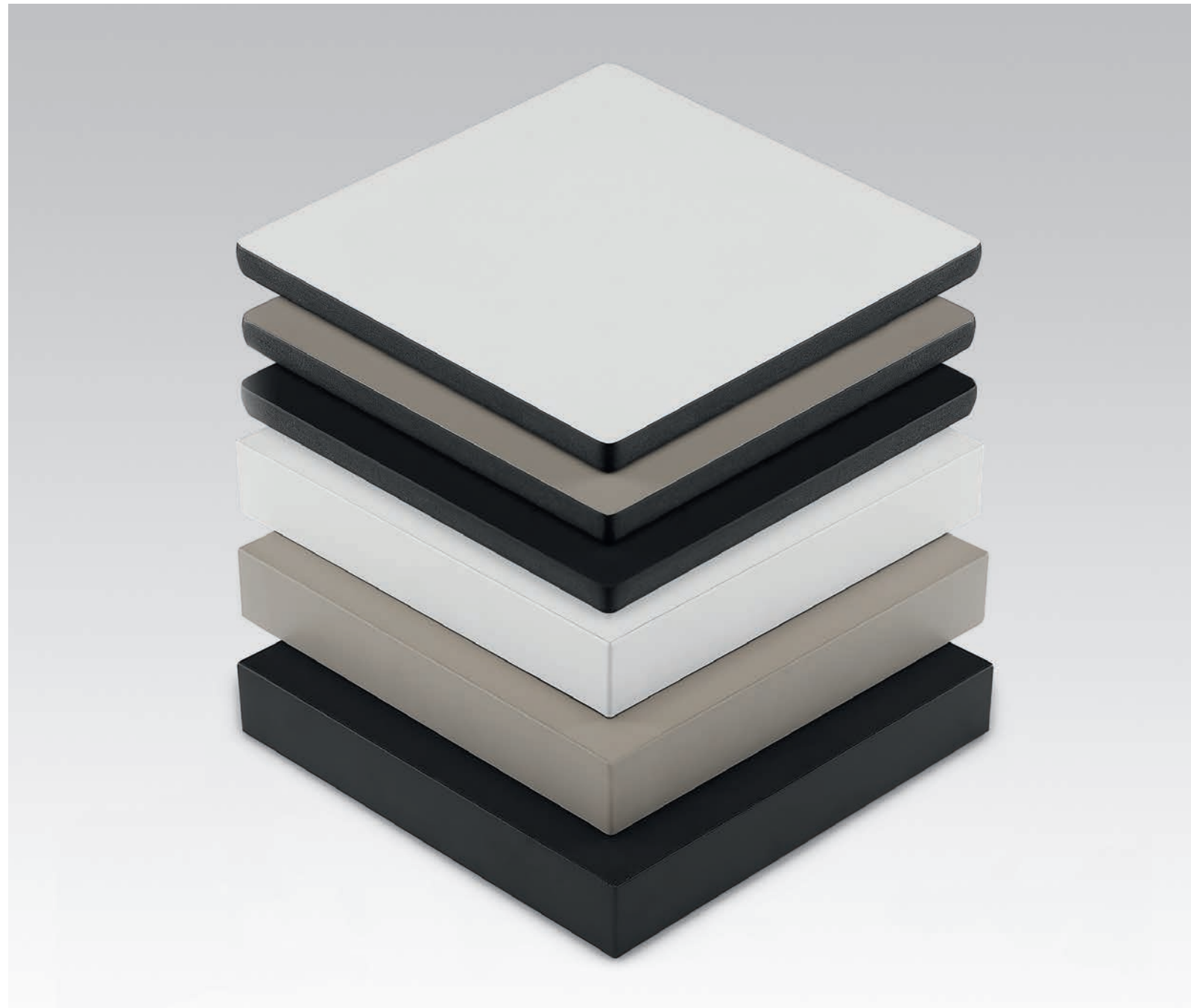

## FENIX

| TABLEROS | PLATEAUX | TABLE  
TOPS | TISCHPLATTEN

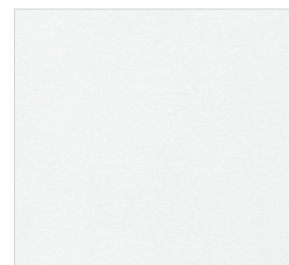

0029

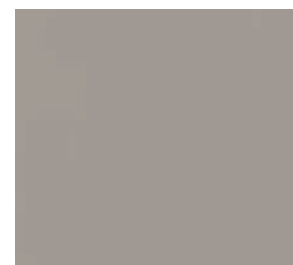

0717

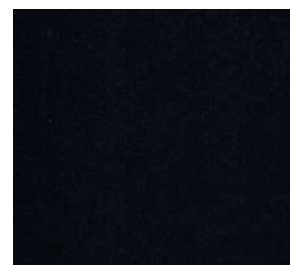

0720

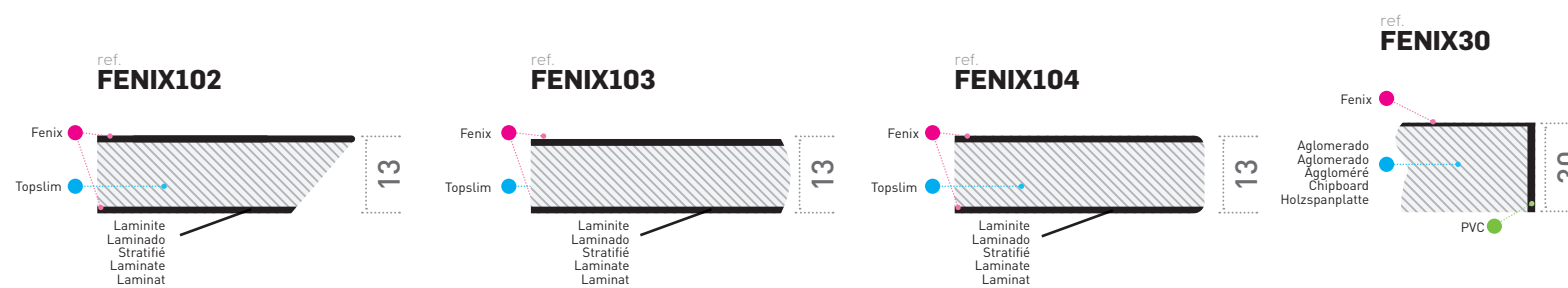

## MONOCHROM

| TABLEROS | PLATEAUX | TABLE TOPS | TISCHPLATTEN

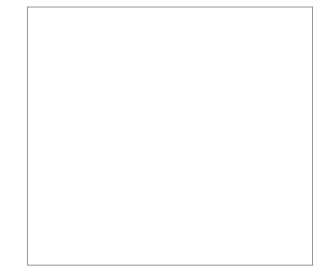

B170 FA



B170 ROC



| LAMINADOS | STRATIFIÉ | LAMINATE | LAMINAT

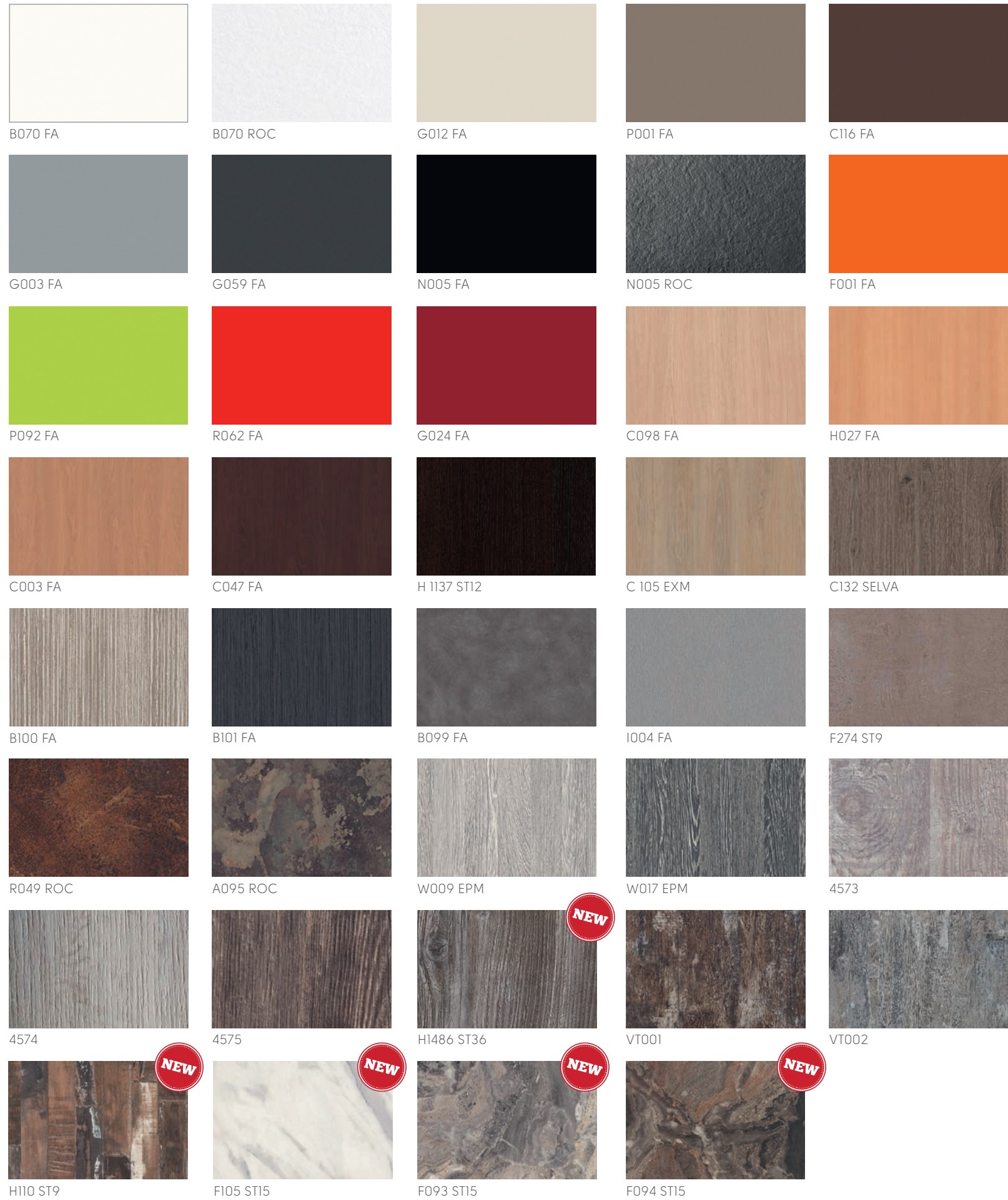

| PVC | PVC | PVC | PVC

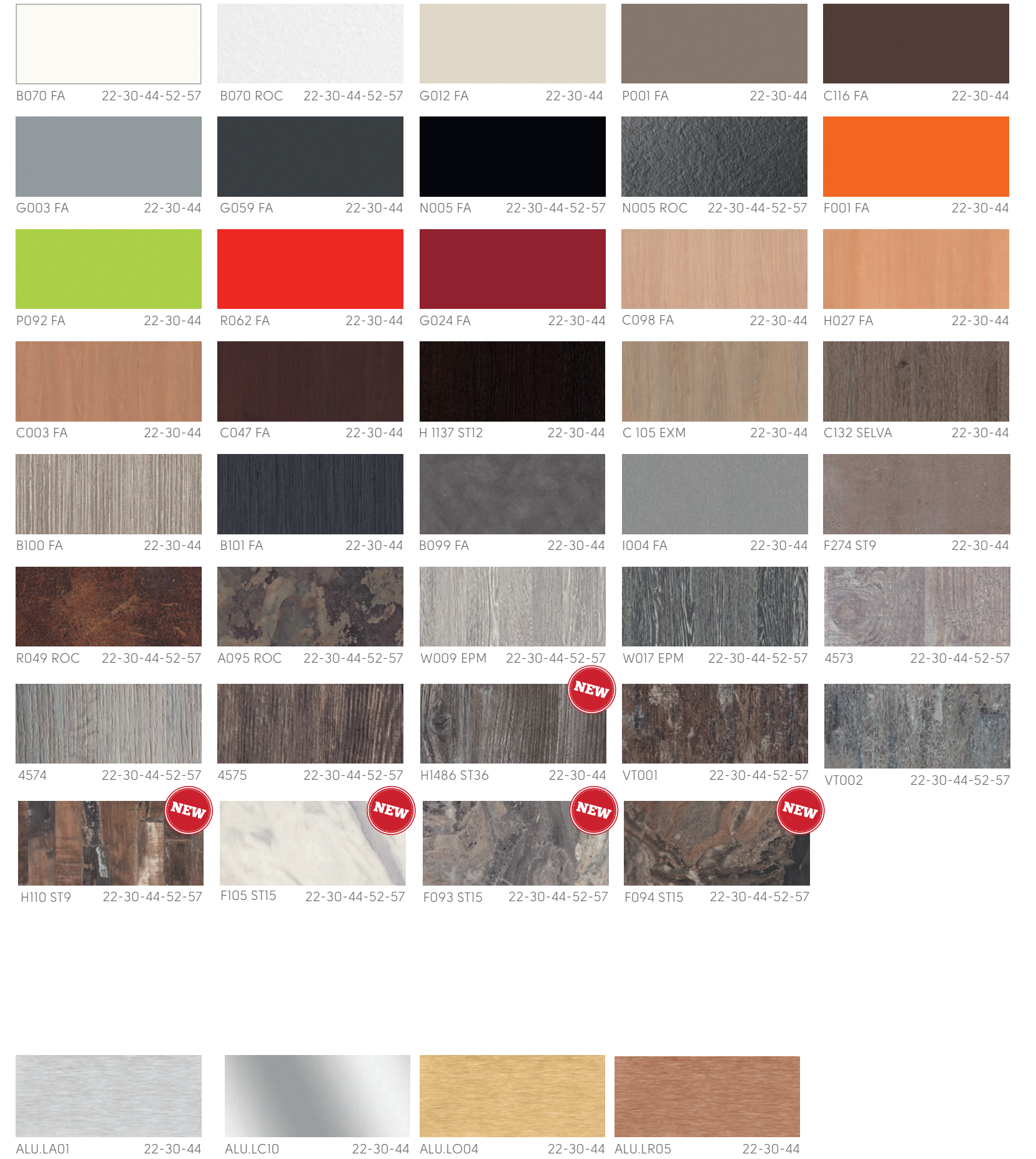



## AM - 19mm

TABLEROS  
PLATEAUX  
TABLE TOPS  
TISCHPLATTEN

ref.  
**AM1219**

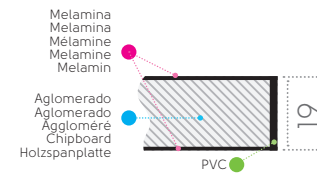

MELAMINA | MELAMINA | MÉLAMINE | MELAMINE | MELAMIN



U763 ST9 ①



U961 ST2 ①

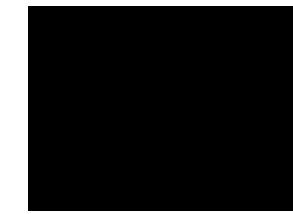

U999 ST2 ①

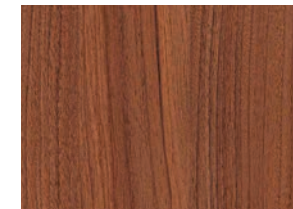

H3734 ST9 ③

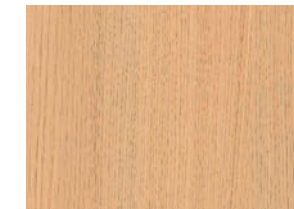

H1334 ST9 ②

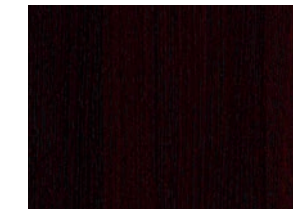

H1137 ST12 ②



H1582 ST15 ③

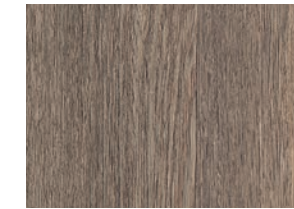

H1115 ST15 ③



## AM - 38mm

TABLEROS  
PLATEAUX  
TABLE TOPS  
TISCHPLATTEN

ref.  
**AM1238**

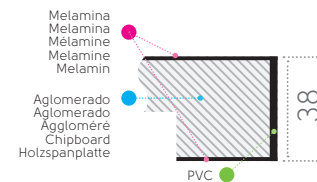

F274 ST9 ③



F509 ST2 ③



4298 ③

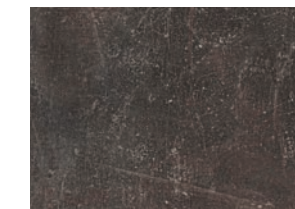

4299 ③



K001 ③



K002 ③

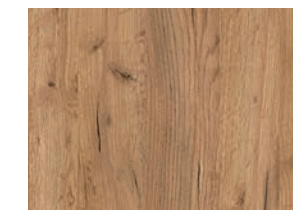

K003 ③

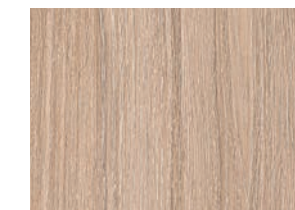

K005 ③

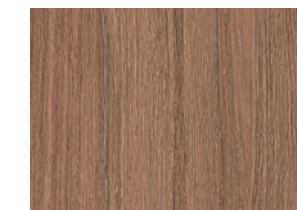

K007 ③

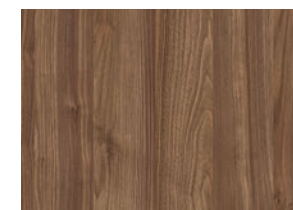

K009 ③



K010 ③



K011 ③

EM MELAMINA | TABLEROS EN MELAMINA | PLATEAUX EN MELAMINE | TOPS IN MELAMINE | MELAMIN TISCHPLATTEN



### LCM - 19mm

| TABLEROS | PLATEAUX | TABLE TOPS | TISCHPLATTEN

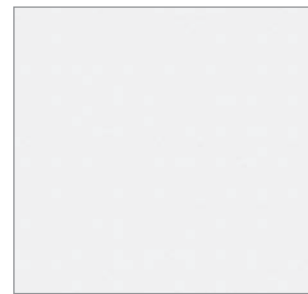
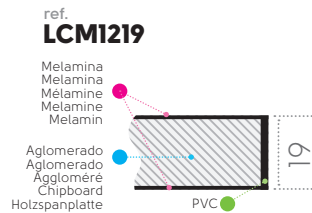

W908 ST2

EM MELAMINA | TABLEROS EN MELAMINA | PLATEAUX EN MELAMINE | TOPS IN MELAMINE | MELAMIN TISCHPLATTEN



### LCM - 38mm

| TABLEROS | PLATEAUX | TABLE TOPS | TISCHPLATTEN

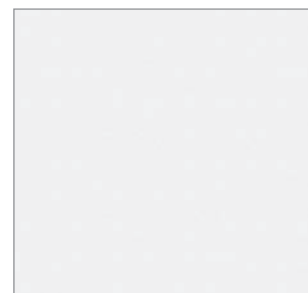
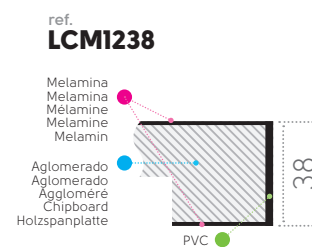

W908 ST2

## COMPACT

| TABLEROS | PLATEAUX | TABLE TOPS | TISCHPLATTEN



### COMPACT | COMPACT | COMPACT | COMPACT | KOMPAKTPLATTE

INTERIOR | INTERIOR | INTÉRIEUR | INDOOR | INNENBEREICH



\* | Posible aplicación en el exterior | Application possible à l'extérieur | Possible application outdoor | Geeignet für den Außenbereich

# TOPPLUS

ALTO BRILLO  
HAUTE BRILLANCE  
HIGH GLOSS  
HOCHGLANZ



Los colores y dimensiones presentados en el catálogo son solamente para ejemplificación  
Les couleurs et dimensions présentées dans le catalogue sont seulement pour exemplification  
The colours and dimensions presented in the catalogue are just exemplifying  
Die farben und größen im katalog sind nur exemplarisch

Nueva colección de tableros fabricados con el laminado alto brillo "TOP PLUS - by redi", con más de doble de resistencia al roce, al desgaste ya la abrasión que el brillo tradicional. Tiene un grosor de 1,2 mm de espesor para conferirle un brillo excelente, sin imperfecciones, pero con la resistencia y las ventajas del laminado. TOP PLUS con un grosor de 20 mm se fabrica con canto ABS de 1 mm bi-color. Un producto de máxima calidad y diseño que revolucionará el mercado de tableros para hostelería.

La nouvelle collection de plateaux en stratifié d'haute brillance "TOP PLUS - by redi", avec le double de la résistance aux rayures, à l'usure et à l'abrasion, que la brillance traditionnel. Le strat de 1,2 mm d'épaisseur donne une excellente brillance sans traces ni défauts, un aspect d'un cristal mais avec une résistance d'un strat. Le plateau fait au totale 20 mm d'épaisseur avec un chant ABS de 1 mm bicouleur. Un produit de qualité supérieure et un design qui va révolutionner le marché des plateaux pour l'hôtellerie.

A new table tops collection, produced with high gloss laminate "TOP PLUS - by redi", with more than double of strength to the risk and abrasion than the traditional. The laminated with 1,2 mm thickness, ensuring an excellent bright, without marks or imperfections, what gives an appearance and advantages to the laminated. TOP-PLUS table top with a thickness of 20 mm and border in ABS of 1 mm bi-color, is a product of high quality and design that comes revolutionize the Contract market.

Eine neue Tischplattenkollektion, hergestellt mit Hochglanzlaminat „TOP PLUS - by redi“, mit mehr als der doppelten Abriebfestigkeit gegenüber traditionellen Laminat. Mit einer Stärke von 1,2 mm bringt es hervorragenden Glanz ohne Mängel und Unvollkommenheiten hervor. Die TOP-PLUS Tischplatte mit einer Stärke von 20 mm und einem zweifarbigen ABS-Rand von 1 mm ist ein Produkt von hoher Qualität und Design, das den Objektmarkt revolutionieren wird.



COLORES DISPONIBLES | COULEURS DISPONIBLES | AVAILABLE COLORS | VERFÜGBARE FARBEN



| HAYA CON COLOR | HÊTRE TEINTÉ | STAINED BEECH | BUCHE GEBEITZT



Los colores y dimensiones presentados en el catálogo son solamente para ejemplificación  
 Les couleurs et dimensions présentées dans le catalogue sont seulement pour exemplification  
 The colours and dimensions presented in the catalogue are just exemplifying  
 Die farben und größen im katalog sind nur exemplarisch

| PIEL SINTÉTICA | PEAU SYNTHÉTIQUE | SYNTHETIC LEATHER | KUNSTLEDER

**A** ATLANTIS



**B ALMA**



PRETO

**B EQUADOR**



CHARCOAL

As cores e dimensões apresentadas neste catálogo são meramente indicativas  
 Los colores y dimensiones presentados en el catálogo son solamente para ejemplificación  
 Les couleurs et dimensions présentées dans le catalogue sont seulement pour exemplification  
 The colours and dimensions presented in the catalogue are just exemplifying  
 Die farben und größen im katalog sind nur exemplarisch

| MICRO FIBRA | MICRO FIBRE | MICROFIBER | MIKROFASER

**B MANILA**



TOFFEE



EBONY

BEIGE

CAMEL

CUOIO

SIENA



ELEPHANT

SAND

LIGHT GREY

DARK GREY

BLACK

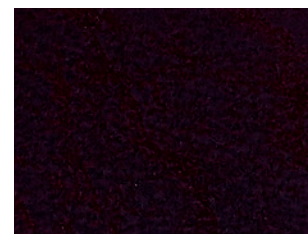

BORDEAUX

Los colores y dimensiones presentados en el catálogo son solamente para ejemplificación  
 Les couleurs et dimensions présentées dans le catalogue sont seulement pour exemplification  
 The colours and dimensions presented in the catalogue are just exemplifying  
 Die farben und größen im katalog sind nur exemplarisch

| PIEL SINTÉTICA | PEAU SYNTHÉTIQUE | SYNTHETIC LEATHER | KUNSTLEDER

**C PANTANAL**



**C BOA**



CHOCOLATE BRANCO CHAMPANHE CINZA PRETO

**C TEXAS**



CAMEL SAND WHITE TAUPE  
ELEPHANT EBONY CHOCOLATE SIENA  
MOSTAZA GREEN BLUE ASH  
DARK GREY BLACK

Los colores y dimensiones presentados en el catálogo son solamente para ejemplificación  
 Les couleurs et dimensions présentées dans le catalogue sont seulement pour exemplification  
 The colours and dimensions presented in the catalogue are just exemplifying  
 Die farben und größen im katalog sind nur exemplarisch

**D PUNTOS**

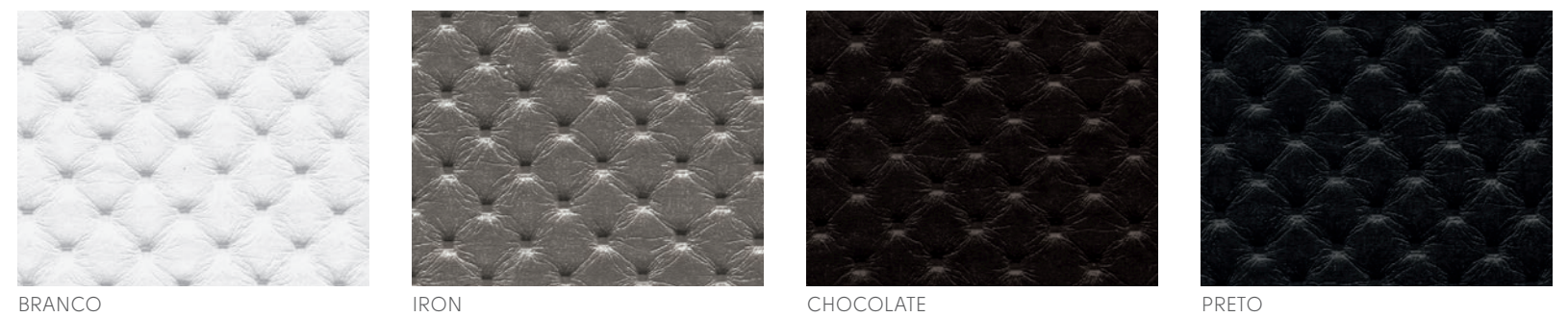

BRANCO IRON CHOCOLATE PRETO

**D MONTE CARLO**

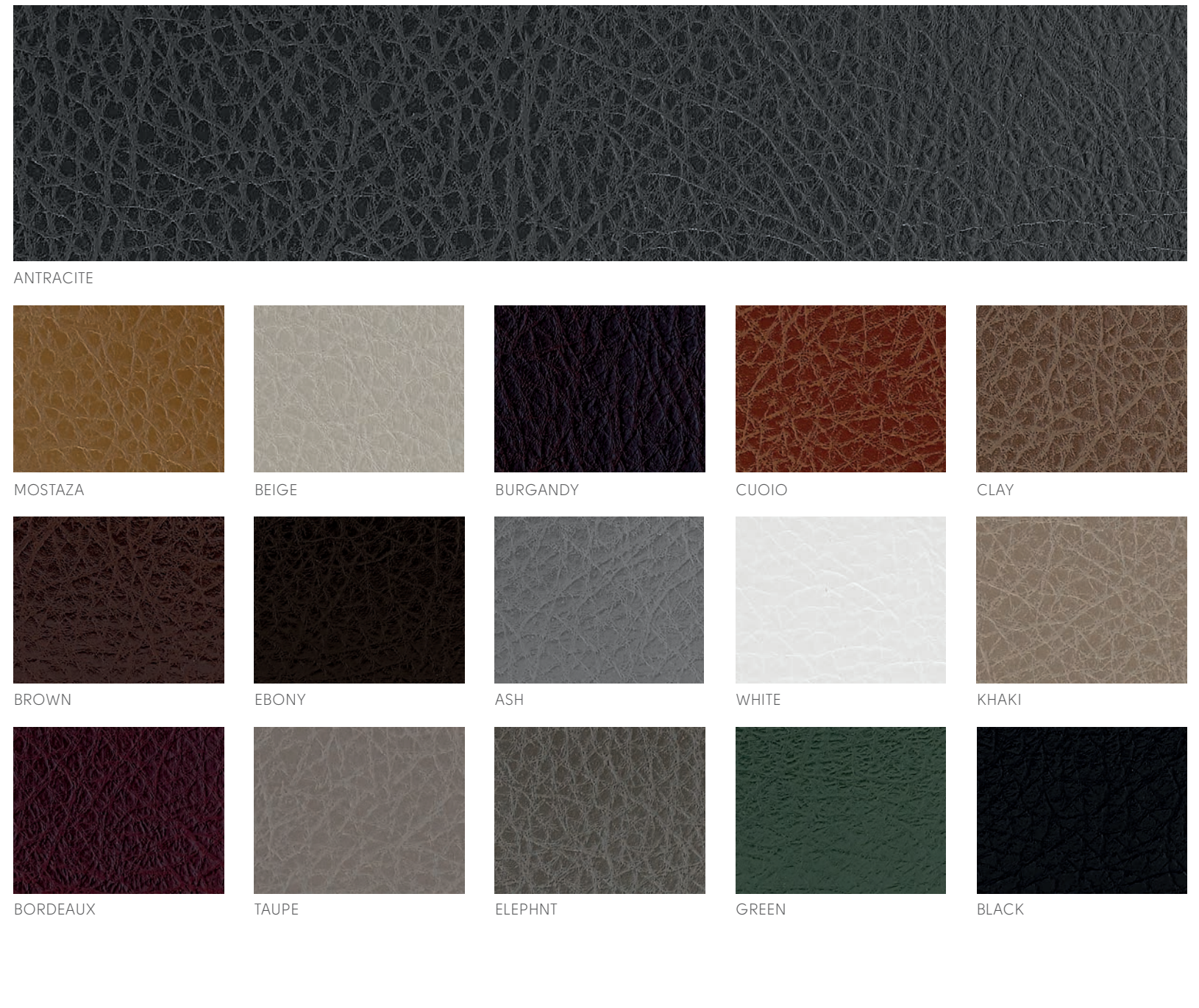

ANTRACITE  
 MOSTAZA BEIGE BURGANDY CUOIO CLAY  
 BROWN EBONY ASH WHITE KHAKI  
 BORDEAUX TAUPE ELEPHANT GREEN BLACK

**E** SELECT



**G** INCA

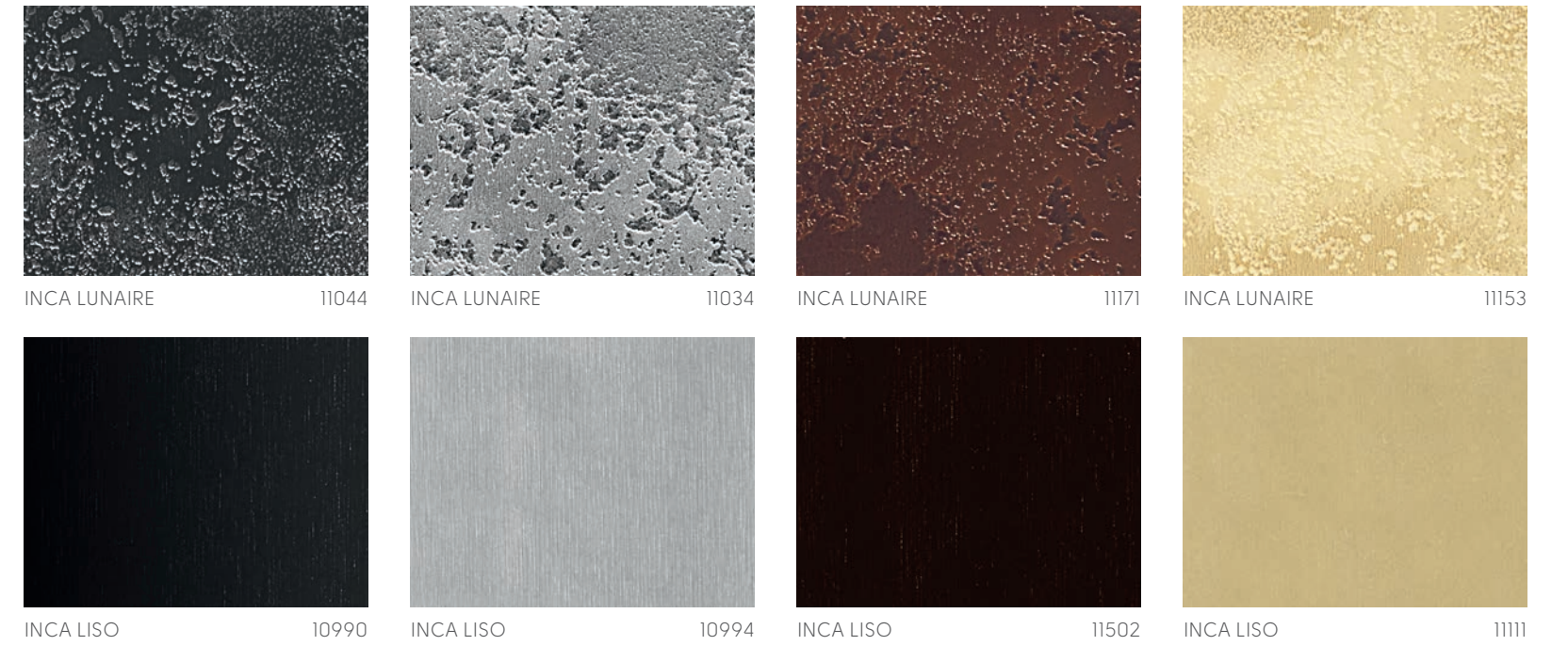

As cores e dimensões apresentadas neste catálogo são meramente indicativas  
 Los colores y dimensiones presentados en el catálogo son solamente para ejemplificación  
 Les couleurs et dimensions présentées dans le catalogue sont seulement pour exemplification  
 The colours and dimensions presented in the catalogue are just exemplifying  
 Die farben und größen im katalog sind nur exemplarisch

**NEW** | FUSION



SHIFT 919ZINC

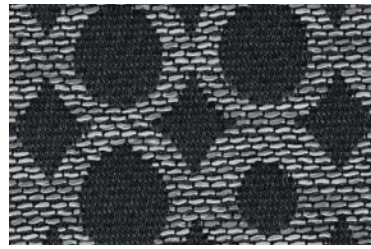

SPIN 919ZINC



SPIN 605CORAL



ASTON 411SPICE



SHIFT 605CORAL



SHIFT 703MINK



ASTON 703MINK



SPIN 703MINK



SPIN 226LIME



ASTON 226LIME

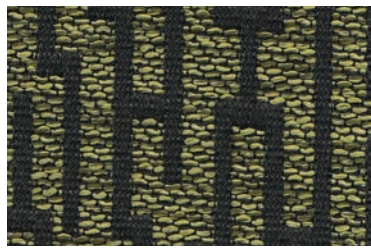

SHIFT 226LIME



ASTON 805 CREAM



SHIFT 843CHAI



SPIN 314MUSTARD

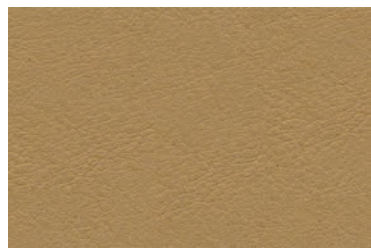

ASTON 300GOLD



SHIFT 314MUSTARD

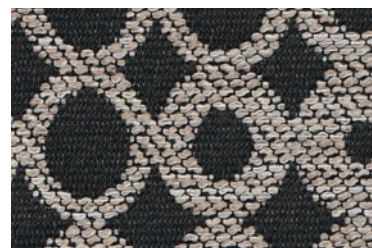

SPIN 805CREAM

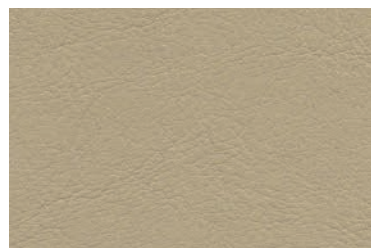

ASTON 823CHBLIS

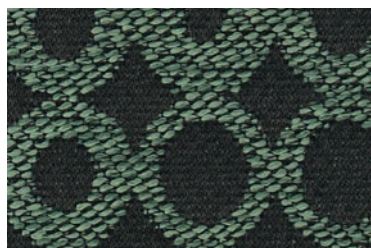

SPIN 215ELM

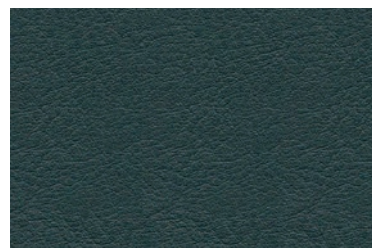

ASTON 203EMERALD



SHIFT 215ELM



SHIFT 151TEAL



ASTON 131AZURE

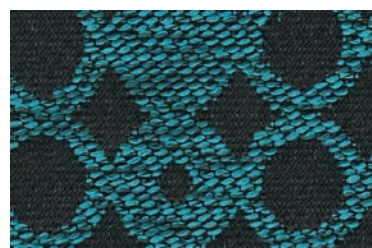

SPIN 151TEAL

**NEW** | FUSION

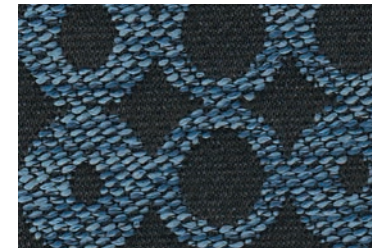

SPIN 104COBALT

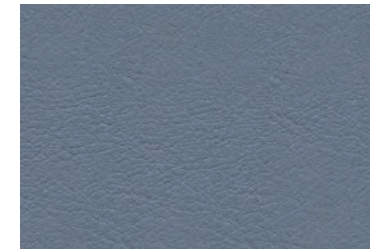

ASTON 198HYACINTH



SHIFT 104COBALT



SHIFT 904PEWTER



ASTON 954GRAPHITE



SPIN 904PEWTER



SPIN 439RASPBERRY



ASTON 409MAGENTA



SHIFT 613PALEPINK

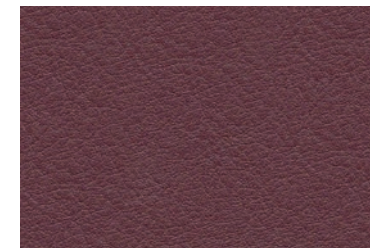

ASTON 414WINE



SHIFT 618BLUSH



SPIN 447CINNAMON

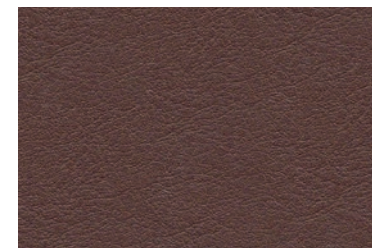

ASTON 817CHESTNUT



SHIFT 447CINNAMON

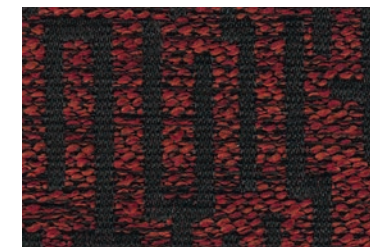

SHIFT 437TUSCANRED

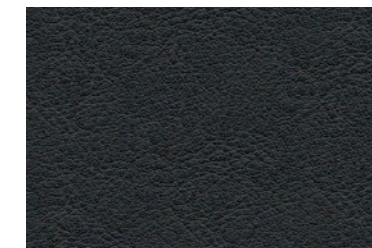

ASTON 900BLACK

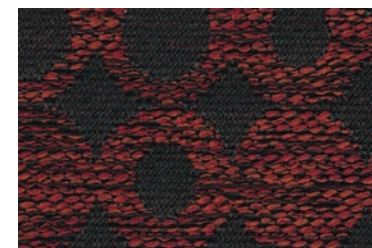

SPIN 437TUSCANRED

As cores e dimensões apresentadas neste catálogo são meramente indicativas  
 Los colores y dimensiones presentados en el catálogo son solamente para ejemplificación  
 Les couleurs et dimensions présentées dans le catalogue sont seulement pour exemplification  
 The colours and dimensions presented in the catalogue are just exemplifying  
 Die farben und größen im katalog sind nur exemplarisch

I GINKGO



**NEW** K LARA



**NEW** **K** LARA



LARA 800 BEIGE



LARA 954 GRAPHITE



ASTON 823 CHABLIS



ASTON 807 MUSHROOM

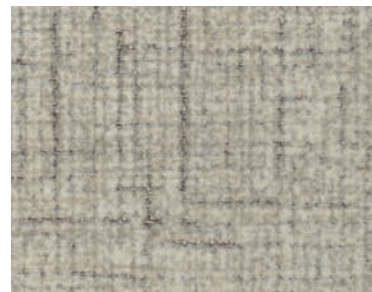

LARA 905 DOVE

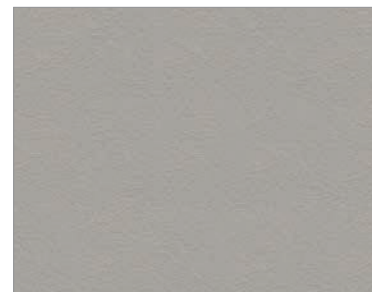

ASTON 905 DOVE

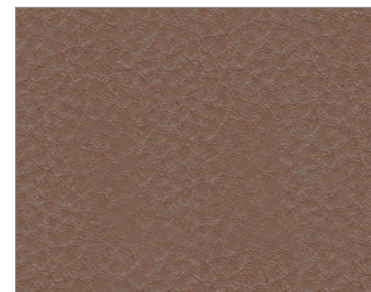

BROOKLAND 801 TAN

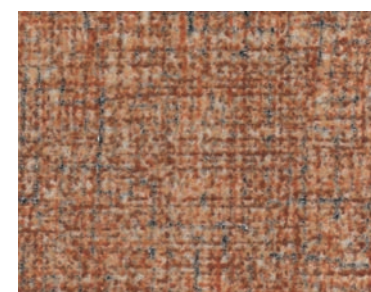

LARA 447 CINNAMON



LARA 858 COBBLE

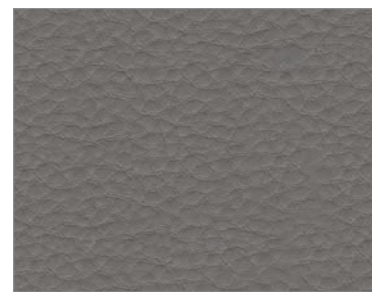

BROOKLAND 501 SMOKE

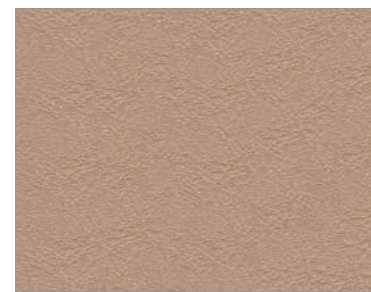

ASTON 877 OYSTER



BROOKLAND 822 HIDE GREEN

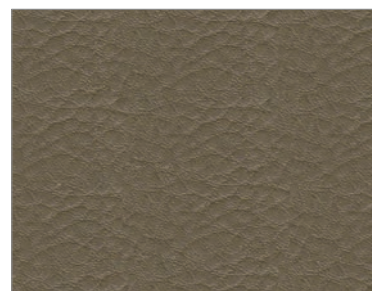

BROOKLAND 807 MUSHROOM

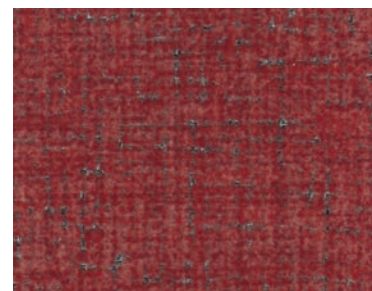

LARA 444 CHERRY



LARA 807 MUSHROOM

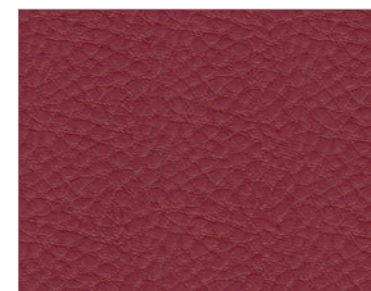

BROOKLAND 444 CHERRY

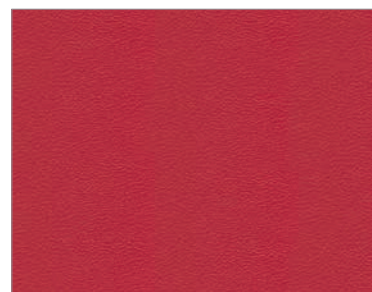

ZEST 424 VERMILLION

Los colores y dimensiones presentados en el catálogo son solamente para ejemplificación  
 Les couleurs et dimensions présentées dans le catalogue sont seulement pour exemplification  
 The colours and dimensions presented in the catalogue are just exemplifying  
 Die farben und größen im katalog sind nur exemplarisch

**NEW** **K** SOLINO



WHITE

F5076054



LIGHTBEIGE

F5076055

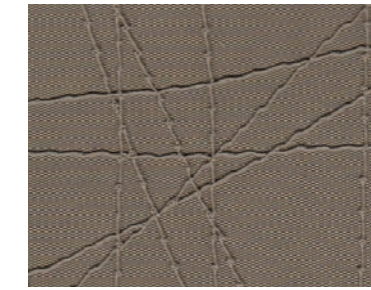

BIRCH

F5076056

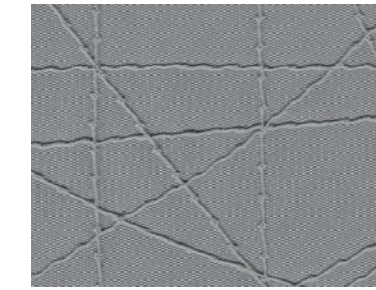

SILVERGREY

F5076060

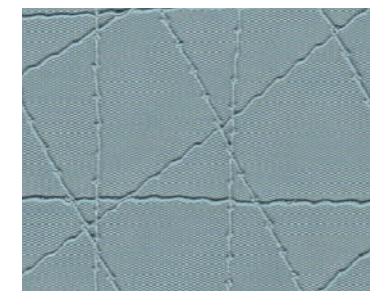

GLACIER

F5076057

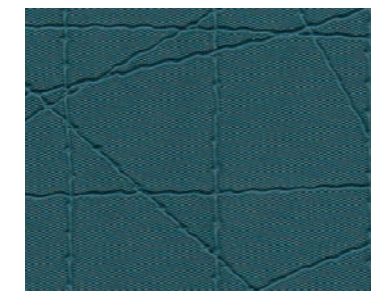

PETROL

F5076086

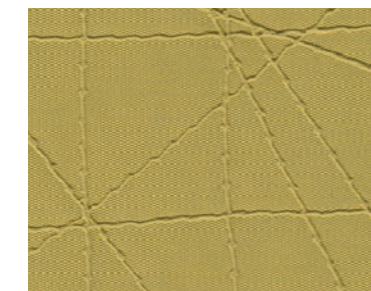

LEMON

F5076084

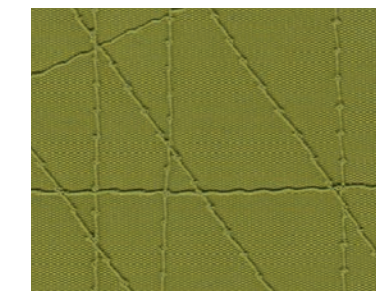

LIME

F5076058

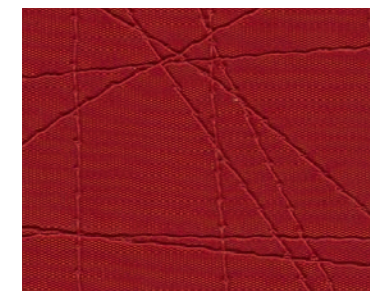

CHERRY

F5076059



RASPBERRY

F5076085



ANTHRACITE

F5076061

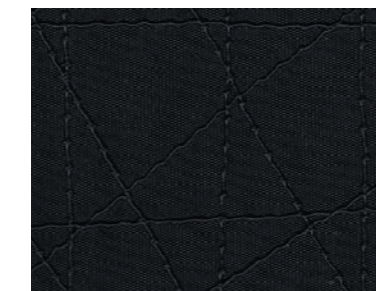

BLACK

F5076064



SHERRY

F5076062

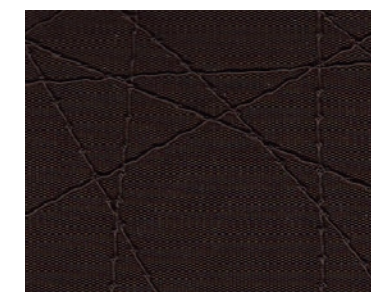

CHOCO

F5076063

Los colores y dimensiones presentados en el catálogo son solamente para ejemplificación  
 Les couleurs et dimensions présentées dans le catalogue sont seulement pour exemplification  
 The colours and dimensions presented in the catalogue are just exemplifying  
 Die farben und größen im katalog sind nur exemplarisch

| PIEL SINTÉTICA | PEAU SYNTHÉTIQUE | SYNTHETIC LEATHER | KUNSTLEDER

| CORCHO | LIÈGE | CORK | KORK



ORACLE

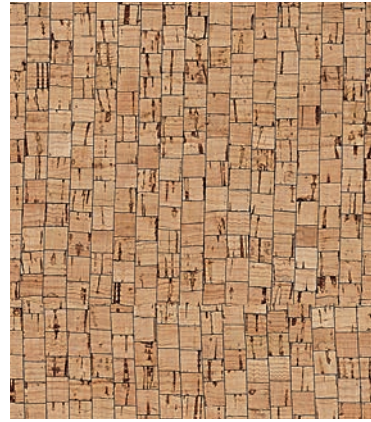

MORPHEUS



TRINITY



LEMON

Los colores y dimensiones presentados en el catálogo son solamente para ejemplificación  
 Les couleurs et dimensions présentées dans le catalogue sont seulement pour exemplification  
 The colours and dimensions presented in the catalogue are just exemplifying  
 Die farben und größen im katalog sind nur exemplarisch

**METAL** | METAL | MÉTAL | METAL | METALL



3000

BRILHO



3014

BRILHO



3015

MATE



3016

TEXTURADO



3018



3019



3030

TEXTURADO



3032

MATE



3034

MATE



3040

VERNIZ



3042

MATE



3046



3048



3050

MATE



3052



3054



3056

MATE



3058

MATE



3060

MATE



3062

MATE



3063



3064

MATE

**METAL** | METAL | MÉTAL | METAL | METALL

PINTURA ESPECIAL | PINTURA ESPECIAL | PEINTURE SPÉCIALE | SPECIAL PAINT | SONDERFARBTON



3070

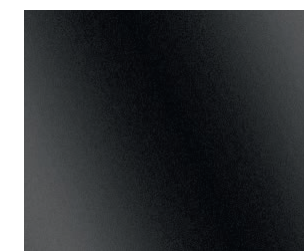

3072



3074



3076

## MESA/N.º LUGARES

DIMENSIONES MESA | N.º PERSONAS | DIMENSIONS TABLE | N.º PERSONNES | DIMENSIONS TABLE | NUMBER OF SEATS | ANZAHL DER SITZPLÄTZE

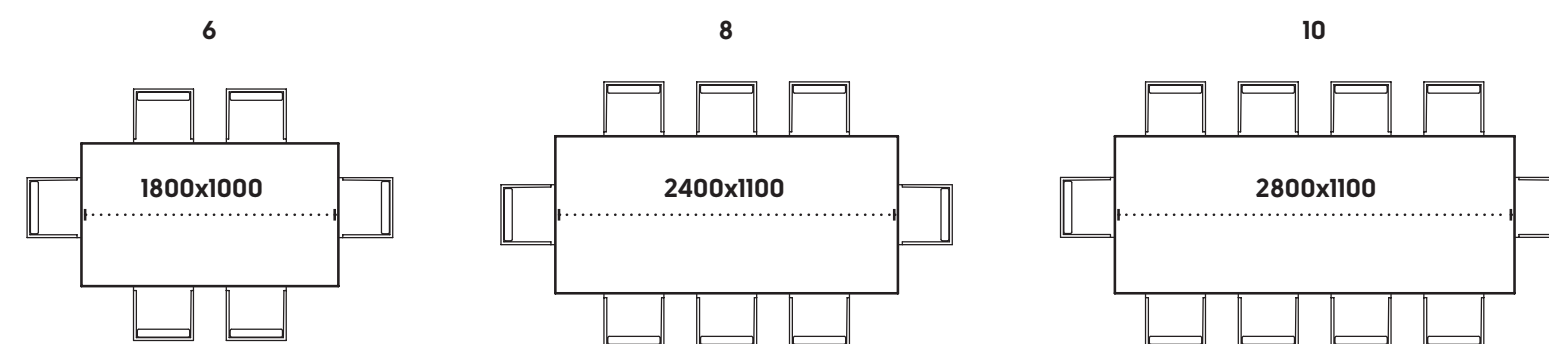
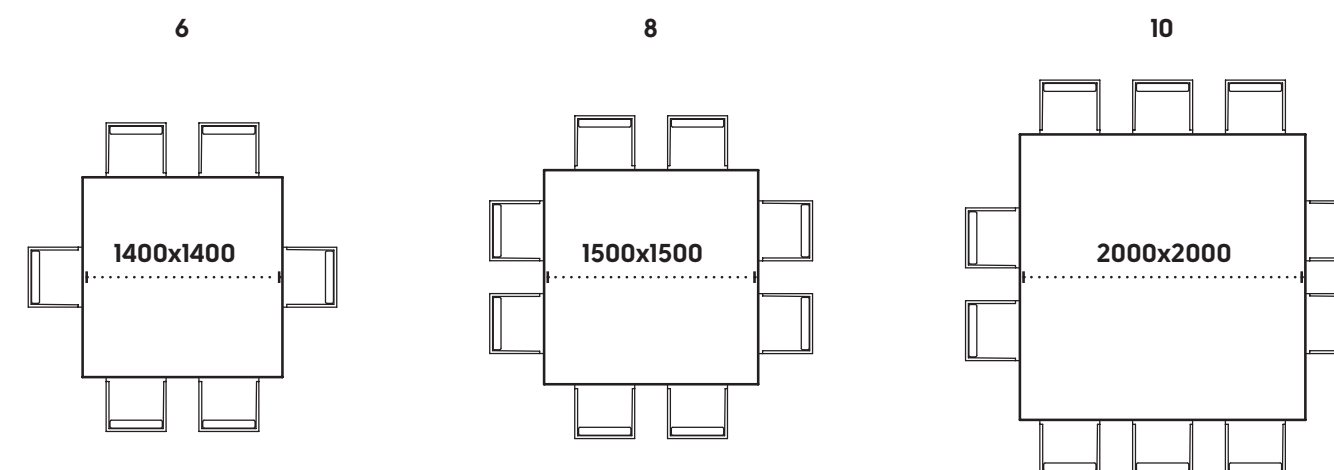
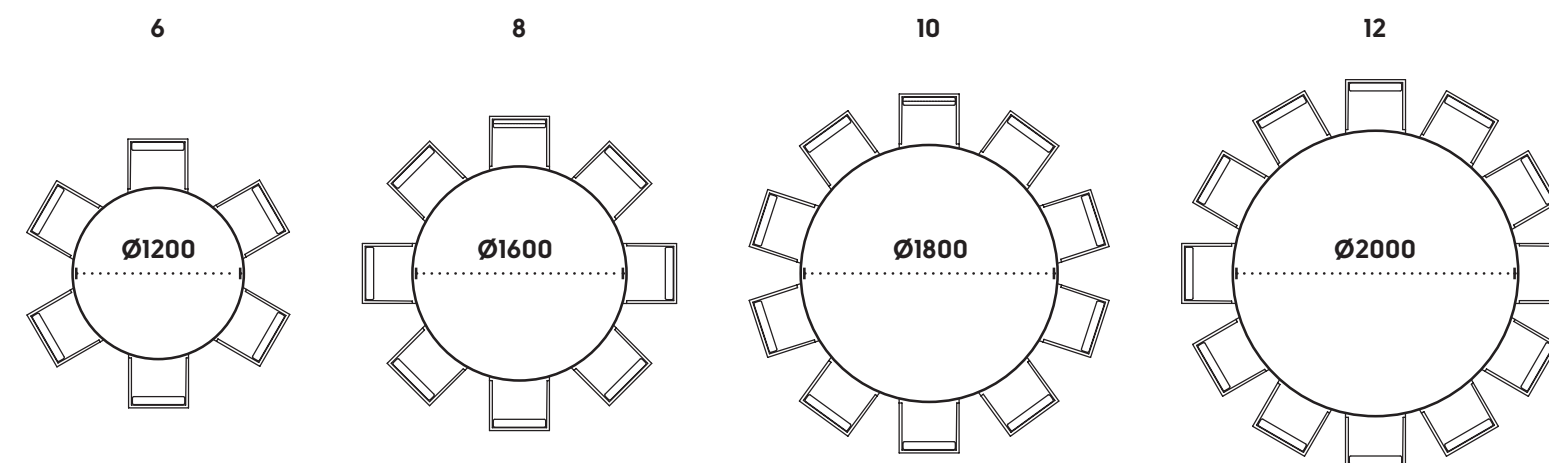

I am pleased to introduce myself as a representative of a factory specializing in the creation of luxury and exclusive design furniture. We take pride in offering products that combine elegance and top-notch craftsmanship, using only unique fabrics and first-class wood.

We understand that each client has specific needs and styles. Therefore, our offerings are tailored to meet your requirements, providing personalized solutions that reflect good taste and distinction.

I would like to invite you to explore our creations, whether through direct purchase or by scheduling an appointment to visit us at our factory in Portugal. During this visit, you will have the opportunity to see our manufacturing process up close and examine the materials we use, allowing you to appreciate the quality and care we put into each piece.

If you are interested in learning more about our products or scheduling a visit, please feel free to contact me. I would be delighted to assist you in finding the perfect furniture solution for your needs.

Thank you for your attention, and I remain at your disposal for any inquiries.

